

FC4210-60

CUTTING PRO

USER'S MANUAL

MANUAL NO. FC4210-UM-151



GRAPHTEC

PREFACE

Thank you for purchasing the FC4210-60 Cutting Plotter. This plotter incorporates a digital servo drive to perform cutting and plotting operations at high speed and high precision.

In addition to applying simple creasing/scoring to cardboard or microflute and cutting marking film or other media, this plotter can also be used as a pen plotter.

To ensure optimum use of its various functions, be sure to read this manual thoroughly before use.

■ Notes on the Use of This Manual

- All rights reserved. No part of this publication may be reproduced, stored in a retrieval system, or transmitted, in any form or by any means, without the prior written permission of Graphtec Corporation.
- The specifications and other information in this manual are subject to change without notice.
- While every effort has been made to supply complete and accurate information about this product, please address any inquiries about unclear information, possible errors, or other comments to your sales representative or nearest Graphtec vendor.
- Notwithstanding the preceding paragraph, Graphtec Corporation assumes no liability for damages resulting from the use of the information contained herein or of the product.

■ Registered Trademarks and Copyrights

- The names of products and brands mentioned herein are the registered trademarks or trademarks of their respective companies.
- All copyrights regarding this manual belong to Graphtec Corporation.

TO ENSURE SAFE AND CORRECT USE

- To ensure safe and correct use of your plotter, read this Manual thoroughly before use.
- After having read this Manual, keep it in a handy location for quick reference as needed.
- Do not permit small children to touch the plotter.
- The following describes important points for safe operation. Please be sure to observe them strictly.

Conventions Used in This Manual

To promote safe and accurate use of the plotter as well as to prevent human injury and property damage, safety precautions provided in this manual are ranked into the three categories described below. Be sure you understand the difference between each of the categories.



DANGER

This category provides information that, if ignored, is highly likely to cause fatal or serious injury to the operator.



WARNING

This category provides information that, if ignored, is likely to cause fatal or serious injury to the operator.





CAUTION



This category provides information that, if ignored, could cause injury to the operator or physical damage to the plotter.

Description of Safety Symbols





The  symbol indicates information that requires careful attention (which includes warnings). The point requiring attention is described by an illustration or text within or next to the  symbol.



The  symbol indicates action that is prohibited. Such prohibited action is described by an illustration or text within or next to the  symbol.



The  symbol indicates action that must be performed. Such imperative action is described by an illustration or text within or next to the  symbol.

Safety Precautions

WARNING

During a plotting or cutting operation, do not touch the writing panel, carriage, and other moving parts.

- Such action may cause human injury.



No touching

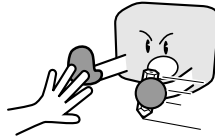

Even when the plotter is stopped, it may suddenly start operating if it receives data, so be sure to keep your hands, hair, and so forth away from the vicinity of the plotter's writing panel and moving parts such as the pen carriage.

- Such action may cause human injury.



Keep away

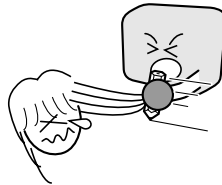

Do not connect the plotter to a non-rated power supply.

- Use of a different supply voltage may result in electrical shock or a fire hazard due to current leakage.



Use prohibited



If the plotter generates smoke, is too hot, emits a strange odor, or otherwise functions abnormally, do not continue using it. Turn off its power and unplug its power cable from the electrical socket.

- Use of the plotter in such status may result in a fire hazard or electrical shock.
- After confirming that smoke is no longer being generated, contact your sales representative or nearest Graphtec vendor to request repair.
- Never try to perform repair yourself. Repair work by inexperienced personnel is extremely dangerous.



Prohibited

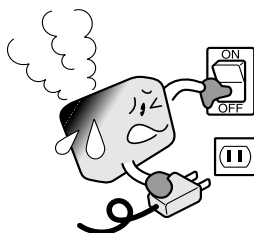

Be sure that the plotter is grounded.

- If the plotter is not grounded, the operator could suffer an electrical shock in case of current leakage.



Ground the Plotter

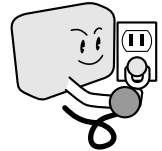

Do not disassemble, repair, or remodel the plotter.

- Such action may cause electrical shock or a fire hazard due to current leakage.
- Contact with the high-voltage parts within the plotter may cause electrical shock.
- If the plotter requires repair, contact your sales representative or nearest Graphtec vendor.



No disassembly



Do not use the plotter in a location where it will be exposed to water, rain or snow.

- Such location may cause electrical shock or a fire hazard due to current leakage.



Avoid water

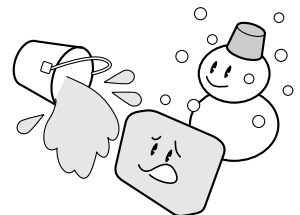

Beware of electrical shock

Safety Precautions (Continued)

WARNING

Do not allow dust or metallic matter to adhere to the power plug.

- A dirty power plug may result in electrical shock or a fire hazard due to current leakage.



Prohibited



Beware of electrical shock

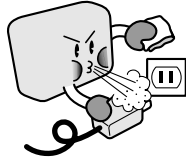

Do not use the power cable if it is damaged.

- Use of a damaged cable may result in electrical shock or a fire hazard due to current leakage.
- Replace the power cable with a new one.



Unplug the power cable from the socket

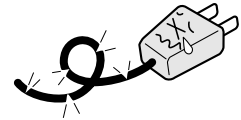

Avoid direct contact with the cutter blade.

- Touching the blade with your bare hand may cause injury.
- During a cutting operation, keep away from the cutter blade.



Avoid contact

CAUTION

Do not use or store the plotter in a location exposed to direct sunlight or the direct draft of an air conditioner or heater.

- Such location may impair the performance of the plotter.



Prohibited

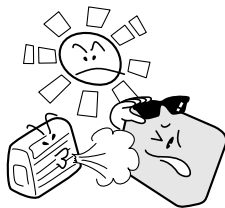

Do not use or store the plotter in an excessively dusty or humid location.

- Such location may impair the performance of the plotter.



Prohibited



Do not place any receptacle containing water or other fluid on top of the plotter.

- Fluid falling inside the plotter may cause electrical shock or a fire hazard due to current leakage.



Avoid water



Beware of electrical shock



Do not install, use, or store the plotter in a location subject to excessive mechanical vibration or electrical noise.

- Such location may impair the performance of the plotter.



Prohibited

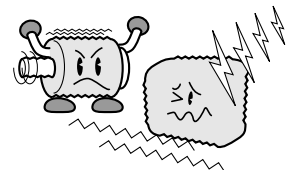

Safety Precautions (Continued)

CAUTION

When disconnecting the power cable or an interface cable, do not pull on the cable.

- Such action will damage the cable, resulting in a fire hazard or electrical shock. Be sure to hold the power cable's plug or the interface cable's connector.



Prohibited

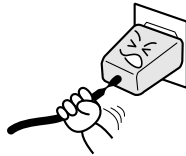

Do not attempt to lubricate the plotter's mechanisms.

- Such action may cause it to break down.



Prohibited



During a cutting or plotting operation, ensure that the movement of the media is not impeded by contact with objects in the plotter's vicinity.

- Such contact could cause misalignment of the cut or plotted results.



No contact

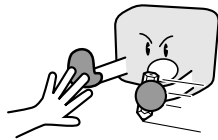

When using indoor illumination such as a fluorescent lamp or a floor lamp, be sure such illumination is positioned at least one meter away from the plotter.

- Insufficient distance may cause the sensors to malfunction and prevent correct detection of the loaded medium.



When using the cutter, beware not to extend the cutter's blade excessively.

- An excessive blade length will damage the cutting mat and impair the plotter's cutting quality.



If water or foreign matter enters inside the plotter, do not continue using it. Turn off its power and unplug its power cable from the electrical socket.

- Use of the plotter in such status may result in electrical shock or a fire hazard due to current leakage.
- Contact your sales representative or nearest Graphtec vendor to request repair.



Unplug the power cable from the socket

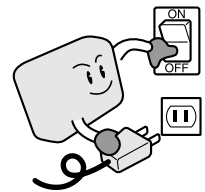

Do not clean the plotter using a volatile solvent (such as thinner or benzine).

- Such action may impair its performance.



Prohibited

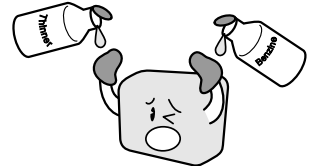

If an edge of the loaded medium comes loose, secure it with drafting tape or a similar means.

- The cutter's blade will break if its tip gets caught on a loose edge of the medium.



Before cutting a medium when you are uncertain of its optimum cutting conditions, run a test cut in advance.

- A cutting operation based on unsuitably specified cutting conditions will place a heavy load on the blade and plotter, causing the blade to break or the plotter to break down.



WARNING:

The United States Federal Communications Commission has specified that the following notice must be brought to the attention of users of this product.

FEDERAL COMMUNICATIONS COMMISSION RADIO FREQUENCY INTERFERENCE STATEMENT

NOTE : This equipment has been tested and found to comply with the limits for a Class A digital device, pursuant to part 15 of the FCC Rules. These limits are designed to provide reasonable protection against harmful interference when the equipment is operated in a commercial environment. This equipment generates, uses, and can radiate radio frequency energy and, if not installed and used in accordance with the instruction manual, may cause harmful interference to radio communications. Operation of this equipment in a residential area is likely to cause harmful interference in which case the user will be required to correct the interference at his own expense.

USE SHIELDED CABLES

To comply with FCC Class A requirements, all external data interface cables and connectors must be properly shielded and grounded. Proper cables and connectors are available from GRAPHTEC's authorized dealers or manufacturers of computers or peripherals. GRAPHTEC is not responsible for any interference caused by using cables and connectors other than those recommended or by unauthorized changes or modifications to this equipment. Unauthorized changes or modifications could void the user's authority to operate the equipment.

Selecting a Power Cable

Be sure to refer to the following tables if you wish to use a cable other than the one supplied as an accessory.

Table 1 100 V to 120 V Power Supply Voltage Range

Plug Configuration	Plug Type	Supply Voltage Selector Settings	Reference Standards	Power Cable
	North America 125 V 10 A	100/120 V	ANSI C73.11 NEMA 5-15 UL498/817/62 CSA22.2 NO.42/21/49	UL Listed Type SJT No.18AWG × 3 300 V, 10 A

Table 2 200 V to 240 V Power Supply Voltage Range

Plug Configuration	Plug Type	Supply Voltage Selector Settings	Reference Standards	Power Cable
	Europe 250 V 10 A	200 V	CEE(7)VII IEC320 CEE13	TYPE: H05VV-F 3 × 1.0 mm ²
	UK 250 V 5 A	200 V	BS1363 BS4491 BS6500	TYPE: H05VV-F 3 × 1.0 mm ²
	Australia 250 V 10 A	200 V	AS3112 AS3109 AS3191	TYPE: OD3CFC 3 × 1.0 mm ²
	North America 250 V 15 A	200 V	ANSI C73.20 NEMA 6-15 UL 198.6	UL Listed Type SJT No.18AWG × 3 300 V, 10 A
	Switzerland 250 V 6 A	200 V	SEV1011 SEV1004 SEV1012	TYPE: H05VV-F 3 × 0.75 mm ²

Precautions on the Handling of Cutter Blades and Other Tools

This plotter employs blades to perform cutting operations. To prevent injury or accidents caused by a cutter blade, be sure to handle the cutter blades very carefully whenever replacing a cutter blade, attaching a cutter plunger to the plotter, and so on.

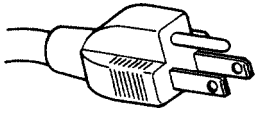
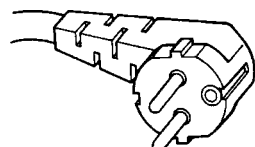
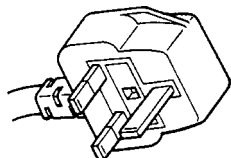
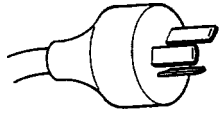
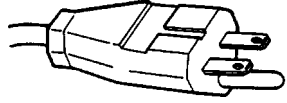
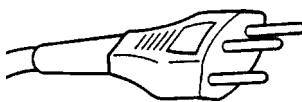
■ The Cutter Blade

The tip of a cutter blade is very sharp. Be careful to avoid unintentionally cutting your finger or stabbing yourself when handling a cutter blade.

When a cutter blade wears out, put it back in the case provided for cutter blades and then dispose of the entire case when it is full of used blades.

■ The Cutter Plunger

Because the tip of the cutter blade is very sharp, be careful not to extend the blade's tip more than necessary. Moreover, when the cutter plunger is not in use, be sure that its blade does not extend beyond the tip of the cutter plunger.

■ Attaching a Cutter Plunger or Creasing/Scoring Tool

To attach a cutter plunger or creasing/scoring tool to the plotter, as illustrated below, insert it fully into the pen holder until it is stopped by the pen bracket's stopper and then firmly secure the cutter plunger by tightening the screw. Contact with a moving plunger or tool when turning on the plotter or during a cutting operation is extremely dangerous, so be sure not to touch the cutter plunger or creasing/scoring tool tip at such times. Be sure to mount the creasing/scoring tool in Pen holder 2.

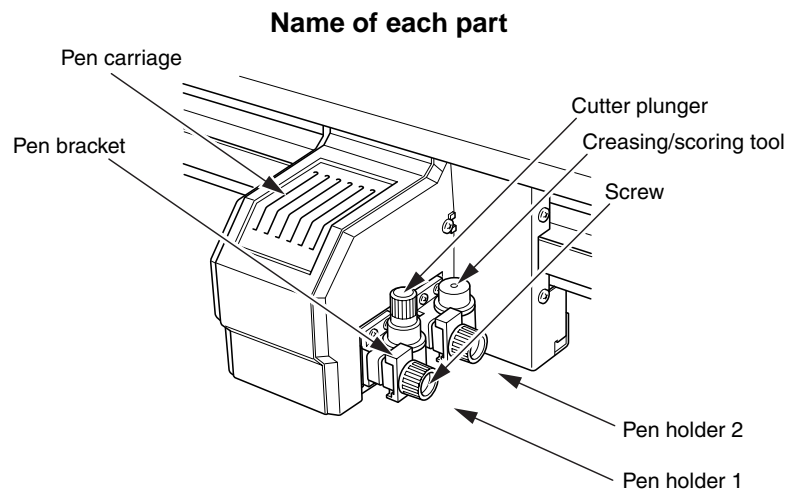

Procedure

- (1) Loosen the pen holder's screw enough to permit passage of the cutter plunger's or creasing/scoring tool's flanges.

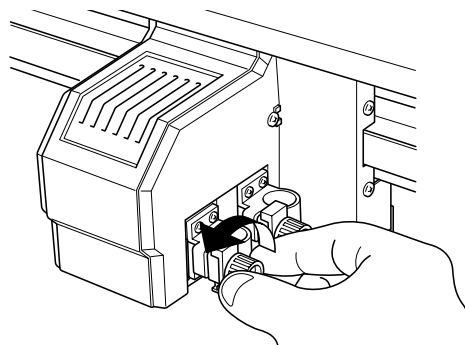

- (2) While pressing the pen holder upward, insert the cutter plunger or creasing/scoring tool fully into the pen holder until it is stopped by the pen bracket's stopper.

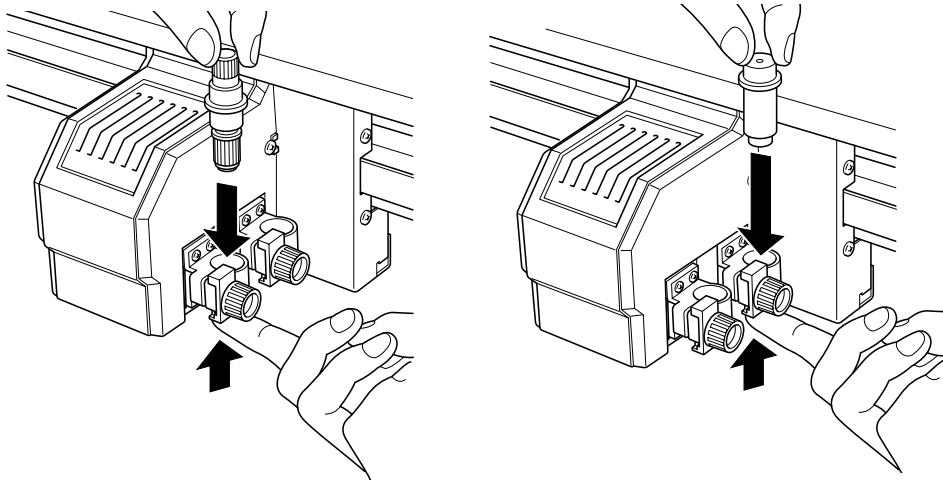

- (3) Mount the pen bracket so that the cutter plunger's or creasing/scoring tool's flange is covered, then tighten the screw.

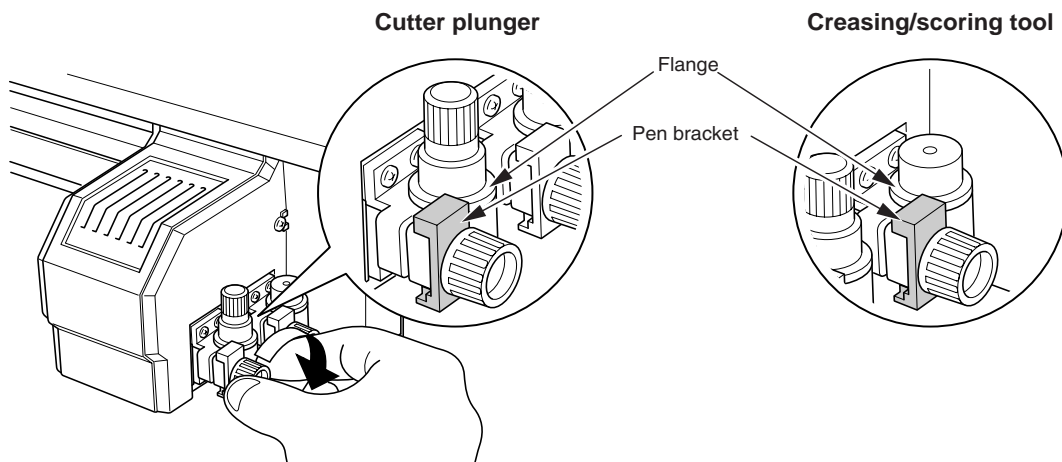

CAUTION

Tighten the screw only after having confirmed that the cutter plunger's or creasing/scoring tool's flange is being held down by the pen bracket as illustrated in the figure below Step (3).

■ The Cutting Conditions

Before cutting a medium when you are uncertain of its optimum cutting conditions, run a test cut in advance. At such time, initially set the cutting conditions as follows: extend the cutter blade's tip a minimum length based on the thickness of the loaded medium, set the CUT FORCE setting to 10, the SPEED setting to 5, and the QUALITY setting to 1. Next, gradually increase the conditions until the optimum test results are achieved.

A cutting operation based on unsuitably specified cutting conditions will place a heavy load on the blade and plotter, causing the blade to break or the plotter to break down.

■ The Creasing/Scoring Conditions

Before performing creasing/scoring on any medium for which the creasing/scoring conditions are unknown, conduct a test in advance. At such time, initially set the cutting conditions as follows: set the CUT FORCE setting to 10, the SPEED setting to 5, and the QUALITY setting to 1. Next, gradually increase the conditions until the optimum test results are achieved. Adequate results will not be obtained if creasing/scoring is performed using inappropriately set values.

After Turning On the Plotter

During a cutting operation and immediately afterward as well as when setting the plotter's functions, the pen carriage and the Y bar may suddenly move.

At such times, keep your hands, hair, and clothing out of the vicinity of the pen carriage and Y bar. Also do not place other objects within that area.

To prevent human injury and poor cutting results, be careful not to allow your hands, hair, clothing, or other foreign objects to get stuck or entangled with the pen carriage or Y bar when using the plotter.

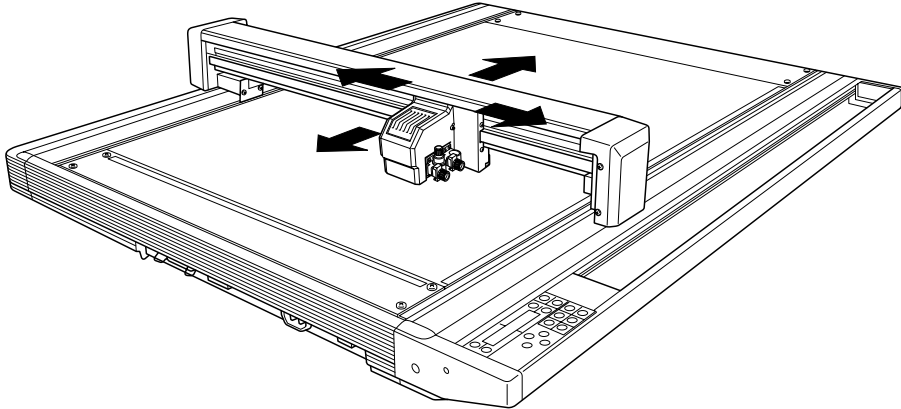

The Warning Label

The warning label shown below is attached to the outside of this plotter's cover. Be sure to strictly observe the precaution indicated in the label.

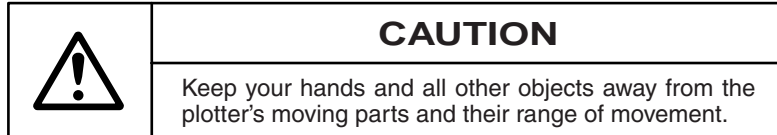

Adhesive Mat

The plotter comes equipped with an adhesive mat as an accessory. Before loading media for creasing/scoring use, paste this adhesive mat to the writing panel. The adhesive mat is a consumable.

■ Using the adhesive mat

The adhesive mat has different adhesive strengths on the surface and reverse side. Use the side with high adhesive strength for pasting to the writing panel, and the side with low adhesive strength for fixing the media in place. The protective film pasted on the surface and reverse side of the adhesive mat is reused for the storage of the removed adhesive mat. Therefore, do not discard it.

Pasting the adhesive mat

When pasting the adhesive mat, follow the procedure described below. (When removing the adhesive mat, follow the procedure in reverse and keep the removed adhesive mat in storage.)

- (1) Remove the protective film from the reverse side of the adhesive mat.
- (2) Paste the adhesive mat to the plotter's writing-panel surface, taking care to prevent the formation of bubbles.
- (3) Remove the protective film from the surface of the adhesive mat.

Precautions on use of the adhesive mat

When cutting general media (e.g., marking film or self-adhesive paper), remove the adhesive mat and paste an adhesive sheet in its place before cutting. For some media (e.g., those with a smooth surface), the adhesive mat may be excessively sticky, making it difficult to remove. When attaching such a medium, make sure the medium is only pasted onto the circumference of the adhesive mat. (If the middle of the medium is warped, lightly press on that part to paste it to the adhesive mat.) Conversely, some media may not become fully pasted onto the adhesive mat. In such a case, fix it in place using, for example, drafting tape.

NOTE

If the cut media rises from the surface during cutting, switch to perforation mode before proceeding. (For details on perforation mode, see Section 5.7, "Setting Perforation Mode.")

If the adhesive mat has lost its adhesive strength

Remove the adhesive mat from the writing panel, and wash it with water. When it is dry, it will become sticky again.

Amount of protrusion of the cutter blade when the adhesive mat is used

Adjust the amount of blade protrusion to the thickness of the medium to be cut, plus an additional 0.1 mm to 0.2 mm. (For details on adjusting the amount of blade protrusion, see Section 2.4, "Adjusting the Blade Length.")

Adhesive Sheet

The plotter comes equipped with an adhesive sheet as an accessory. Before loading general media (e.g., marking film or self-adhesive paper) in place, paste this adhesive sheet to the writing panel. The adhesive sheet is a consumable.

■ Using the adhesive sheet

The adhesive sheet has different adhesive strengths on the surface and reverse side. Use the side with high adhesive strength for pasting to the writing panel, and the side with low adhesive strength for fixing the media in place.

Pasting the adhesive sheet

When pasting the adhesive sheet, follow the procedure described below.

- (1) Remove the protective film from the white side of the adhesive sheet.
- (2) Paste the adhesive sheet to the plotter's writing-panel surface, taking care to prevent the formation of bubbles.
- (3) Remove the protective film from the yellow side of the adhesive sheet.

Precautions on the adhesive sheet

When loading media for creasing/scoring, remove the adhesive sheet and paste the adhesive mat in its place.

For some media (e.g., that with a smooth surface), the adhesive sheet may be excessively sticky, making it difficult to remove the media. When attaching such a medium, make sure it is only pasted to the adhesive sheet on its circumference. (If the middle part of the medium is warped, lightly press on that part to paste it to the adhesive sheet.) Conversely, some media may not become fully pasted onto the adhesive sheet. In such a case, fix it in place with, for example, drafting tape.

If the adhesive sheet has lost its adhesive strength

Remove the adhesive sheet from the writing panel, and replace it with a new adhesive sheet.

Amount of protrusion of the cutter blade when the adhesive sheet is used

For details on adjusting the amount of blade protrusion, see Section 2.4, "Adjusting the Blade Length."

Daily Maintenance and Storage

■ Daily Maintenance

During the course of daily plotter operation, be sure to observe the following precautions.

- Never lubricate the mechanisms of the plotter.
- If the plotter's casing becomes dirty, wipe the soiled areas using a dry cloth or a cloth that has been moistened in a neutral detergent diluted with water.
Never use thinner, benzine, alcohol, or similar solvents; they will damage the casing's finish.
- If the writing panel becomes dirty, wipe it using a dry cloth. In case of stubborn stains, use a cloth that has been moistened in a neutral detergent diluted with water.
Never use benzine, thinner, alcohol, or similar solvents to clean the panel.

■ Storing Your Plotter

To store the plotter when it is not being used, be sure to observe the following points:

- Remove the cutter plunger, creasing/scoring tool or plotter pen attached to the pen holder and store it.
- To protect the plotter from dust and dirt, cover it with a cloth.
- Avoid storing the plotter in places subject to direct sunlight or high temperatures.

CONTENTS

PREFACE	i
■ Notes on the Use of This Manual	i
■ Registered Trademarks and Copyrights	i
TO ENSURE SAFE AND CORRECT USE	ii
PRECAUTIONS ON THE HANDLING OF CUTTER BLADES AND OTHER TOOLS	viii
■ The Cutter Blade	viii
■ The Cutter Plunger	viii
■ Attaching a Cutter Plunger or Creasing/Scoring Tool	viii
■ The Cutting Conditions	ix
■ The Creasing/Scoring Conditions	ix
AFTER TURNING ON THE PLOTTER	x
THE WARNING LABEL	x
ADHESIVE MAT	xi
■ Using the adhesive mat	xi
ADHESIVE SHEET	xii
■ Using the adhesive sheet	xii
DAILY MAINTENANCE AND STORAGE	xiii
1. UNPACKING YOUR PLOTTER	1-1
1.1 Checking the Standard Accessories	1-1
1.2 Plotter Nomenclature	1-2
2. CUTTER BLADES AND PENS	2-1
2.1 Types and Features of Cutter Blades	2-1
2.2 Nomenclature of Cutter Plungers	2-2
2.3 Replacing a Cutter Blade	2-3
2.4 Adjusting the Blade Length	2-4
3. PREPARING FOR A CUTTING OPERATION	3-1
3.1 Control Panel	3-1
3.2 The Tree Structure of Menus	3-3
3.3 Connecting Your Plotter to a Computer	3-4
3.4 Turning on the Plotter and Initialization	3-5
3.5 Securing a Medium	3-6
4. SPECIFYING THE PEN CONDITIONS	4-1
4.1 The Cutter Plunger's Conditions	4-1
4.2 Selecting a Set of Cutting Conditions	4-2

4.3	Specifying the Cutting Conditions	4-3
4.3.1	Display When the Condition-Setting Key is Pressed	4-3
4.3.2	Setting the Blade Type and Offset	4-4
4.3.3	Setting the Creaser	4-5
4.3.4	Setting the Cutting Force and Pen Force (Creasing Force)	4-7
4.3.5	Setting the Speed	4-8
4.3.6	Setting the Quality	4-9
4.3.7	Setting Cutting Conditions in THICK MODE	4-10
4.4	Running a Cutting Test	4-11
4.4.1	When the Blade Type is Set for Creaser	4-13
5.	USING THE BASIC FUNCTIONS	5-1
5.1	Specifying the Origin Point of the Plotting Area	5-1
5.2	Using the COPY function	5-2
5.3	Specifying the Corrective Values for the Pen Width	5-5
5.4	Raising or Lowering the Pen	5-7
5.5	Clearing the Plotter's Internal Buffer Memory	5-8
5.6	Specifying the Pen Conditions	5-9
5.7	Setting Perforations	5-10
6.	USING THE MAIN FUNCTIONS	6-1
6.1	Selecting the ORIGIN POINT Position in HP-GL Mode	6-1
6.2	Specifying the Effective Cutting/Plotting AREA	6-2
6.3	Enabling the ROTATE Mode to Rotate the Coordinate Axes	6-4
6.4	Specifying the THICK MODE Settings	6-6
6.5	Enabling the MIRROR Mode to Produce a Mirror Image	6-7
6.6	Specifying the Pen SORT Function	6-9
7.	USING THE REGISTRATION FUNCTION	7-1
7.1	Overview of Automatic Registration Mark Recognition	7-1
7.2	Specifying the Registration MARK Mode	7-5
7.3	Detection of Registration Marks	7-8
7.3.1	Specifying Manual Registration Mark Recognition	7-8
7.3.2	Specifying Two-Point (2 POINT) Recognition	7-10
7.3.3	Specifying Three-Point (3 POINT) Recognition	7-11
7.3.4	If Mirror-Mark Cutting is Enabled	7-13
7.4	Selecting the Registration MARK TYPE	7-14
7.5	Specifying the Registration MARK SIZE	7-18
7.6	Specifying Other Parameters Related to Registration Marks	7-19
7.6.1	Adjusting the Distance Precision for Registration Marks	7-19
7.6.2	Adjusting the Registration Mark Sensor	7-21
7.6.3	Adjusting the Sensor by Printing a Cross Pattern	7-23
7.6.4	Specifying the Registration MARK OFFSET	7-25
7.7	Specifying Registration-Mark Detection Options	7-27
7.7.1	Setting the Speed of Registration-mark Detection	7-27
7.7.2	Setting the Registration-mark Level	7-28
7.7.3	Setting the Registration-mark Cutting Function	7-30
7.7.4	Setting the Sensing Intervals	7-32

8. USING THE OPTIONAL FUNCTIONS	8-1
8.1 Setting the PEN UP SPEED	8-1
8.2 Setting the Cutter Blade's OFFSET FORCE	8-2
8.3 Setting the Cutter Blade's OFFSET ANGLE	8-3
8.4 Setting the STEP PASS	8-4
8.5 Selecting the LENGTH UNIT	8-5
8.6 Setting the DISTANCE ADJUST Values	8-6
9. USING THE SPECIAL FUNCTIONS	9-1
9.1 Description of the Special Functions	9-1
9.2 Setting the Special Functions	9-3
10. TEST MODES AND TROUBLESHOOTING PROCEDURES	10-1
10.1 Using the TEST Modes	10-1
10.1.1 Printing a List of the Currently Selected Conditions	10-1
10.1.2 Running the SELF TEST	10-2
10.1.3 Using the Character Dump Mode	10-3
10.2 Troubleshooting Procedures	10-4
10.2.1 The Plotter Doesn't Operate After Being Turned On	10-4
10.2.2 The Cut Results Are Unsatisfactory	10-5
10.2.3 Creasing/Scoring	10-7
10.2.4 The Coordinate Axes Cannot Be Correctly Aligned	10-8
10.3 Error Messages	10-9
10.3.1 General Error Messages	10-9
10.3.2 Error Messages in GP-GL Command Mode	10-10
10.3.3 Error Messages in HP-GL Command Mode	10-11
11. INTERFACES	11-1
11.1 Setting Up the Centronics-Compatible Parallel Interface	11-1
11.2 Setting Up the RS-232C Serial Interface	11-1
11.3 Specifying the STEP SIZE	11-2
11.4 Specifying the RS-232C Interface Conditions	11-3
11.5 Selecting the COMMAND Mode	11-5
12. SPECIFICATIONS	12-1
12.1 General Specifications	12-1
12.2 Option	12-2
12.3 External Dimensions	12-3
INDEX	I-1

1. UNPACKING YOUR PLOTTER

This chapter describes how to unpack your plotter and also explains the names and functions of its main parts.

1.1 Checking the Standard Accessories

After unpacking the plotter, check that the standard accessories listed below are all present. If an accessory is missing, contact your sales representative or nearest Graphtec vendor.

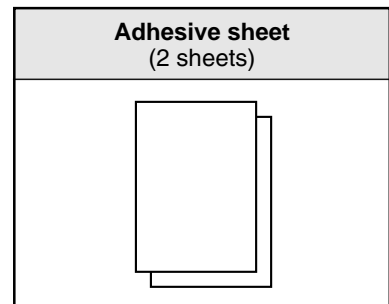
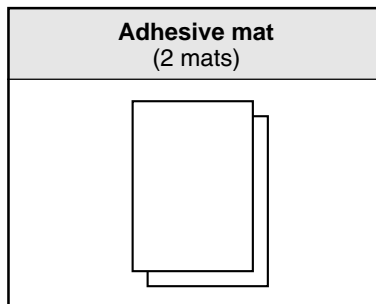
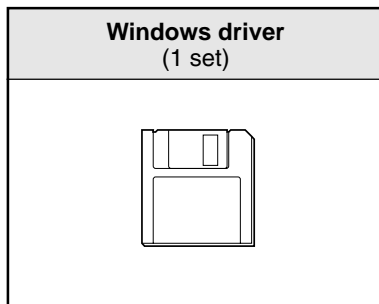
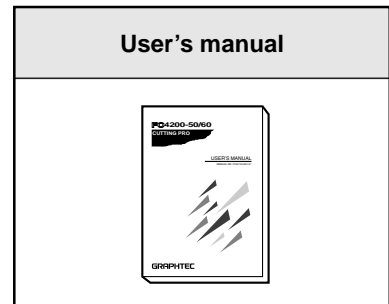
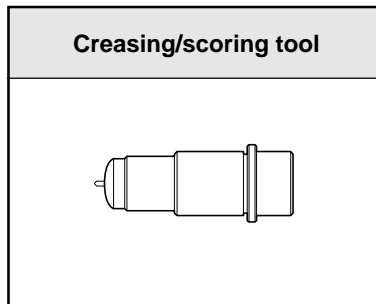
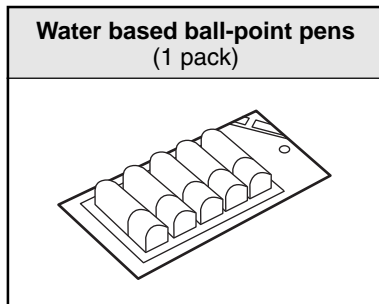
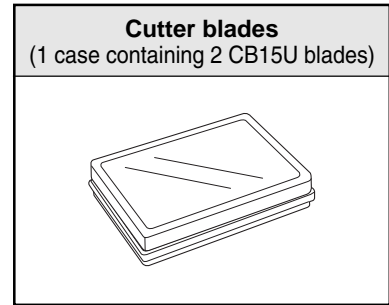
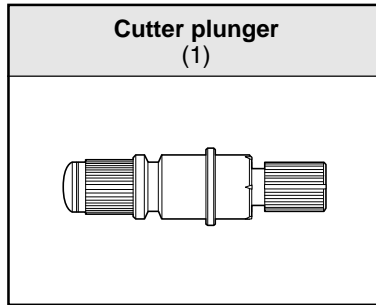
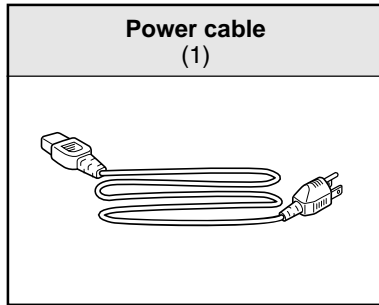

1.2 Plotter Nomenclature



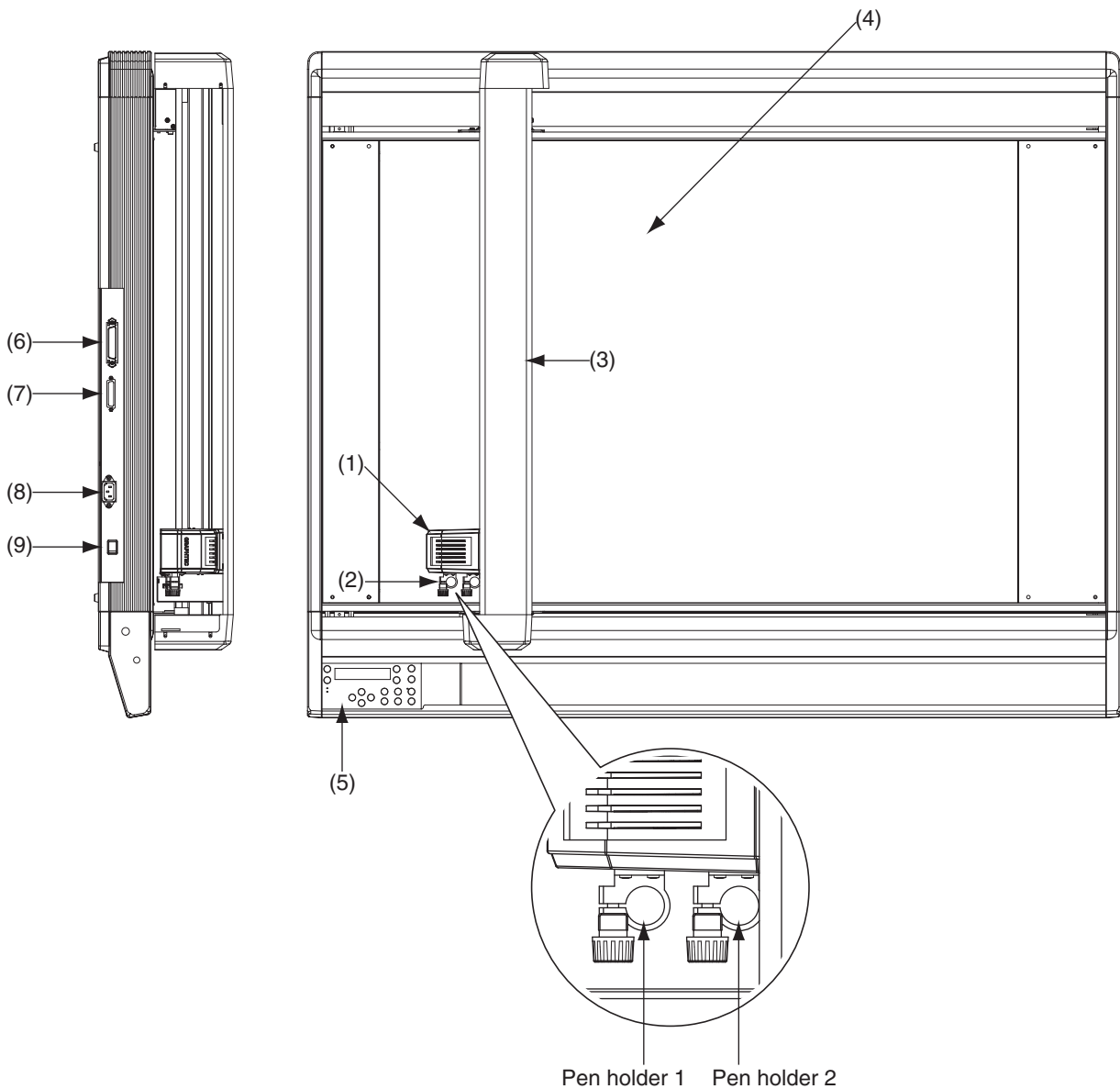

- (1) **Pen carriage** : Drives the cutter plunger/pen/creasing tool to the left/right.
- (2) **Pen holder** : Holds the cutter plunger/pen/creasing tool and drives it up/down.
- (3) **Y bar** : Holds the pen carriage; moves left/right.
- (4) **Writing panel** : Cutting/plotting/creasing is performed here.
- (5) **Control panel** : Used to set and use the plotter's various functions.
- (6) **Centronics parallel interface connector** : Used to connect the plotter to a computer by cable via the Centronics-compatible parallel interface.
- (7) **RS-232C serial interface connector** : Used to connect the plotter to a computer by cable via the RS-232C serial interface.
- (8) **AC line inlet** : Connect one end of the power cable here and the other end to an electrical socket.
- (9) **Power switch** : Controls the on/off status of the power supply to the plotter.

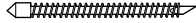

2. CUTTER BLADES AND PENS

2.1 Types and Features of Cutter Blades

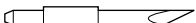
Becoming familiar with the types and features of cutter blades compatible with your plotter will enable you to select the best combination of cutter blade and cutting medium for optimum cutting results.

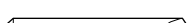
Blade's shape and part no.	Blade diameter	Blade offset	Compatible plunger	Features
CB09UA 	φ 0.9 mm	0.45	PHP32-CB09N	The standard blade for cutting color adhesive-backed film, it is suitable for cutting media of a thickness under 0.25 mm. Maximum cut distance: 4000 m.
CB15U 	φ 1.5 mm	0.75	PHP32-CB15N	Capable of cutting thicker film than the CB09UA blade, this blade is suitable for cutting media of a thickness ranging from 0.25 to 0.5 mm.
CB15UA 	φ 1.5 mm	0.75	PHP32-CB15N	Use this blade to cut high-luminosity reflecting film.
CB15U-K30 	φ 1.5 mm	0.75	PHP32-CB15N	Use this blade to cut rubber for sandblasting. This blade has the sharpest angle and a longer cutting edge. It is ideal for cutting media of a thickness ranging from 0.5 to 1.5 mm.
CB15-10C (Ceramic) 	φ 1.5 mm	0.5	PHP31-CB15	This blade is made from the hardest material but has a low resistance to impact. It is suitable for cutting media with a thickness under 0.05 mm.
CB15-05S (Sapphire) 	φ 1.5 mm	0.25	PHP31-CB15	For cutting strip film (for use as block copy), this blade is ideal for cutting media with a thickness under 0.05 mm.



CAUTION



When handling cutter blades, be careful to avoid cutting your fingers or other parts of your body.

2.2 Nomenclature of Cutter Plungers



CAUTION



When handling cutter blades, be careful to avoid cutting your fingers or other parts of your body.

With this plotter, the blade is mounted into its corresponding cutter plunger for use. There are two types of cutter plungers available, which vary according to the diameter of the blade to be mounted (the ϕ 1.5-mm plunger is provided as a standard accessory). Be sure to mount the cutter blade in a cutter plunger that is compatible with the diameter of the cutter blade.

■ Structure of the Cutter Plunger

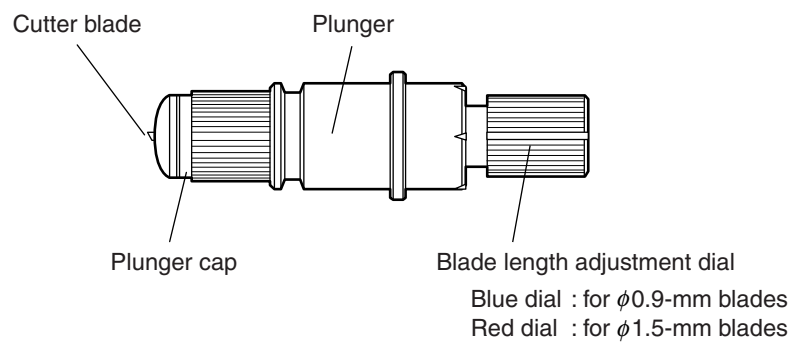

2.3 Replacing a Cutter Blade

Procedure

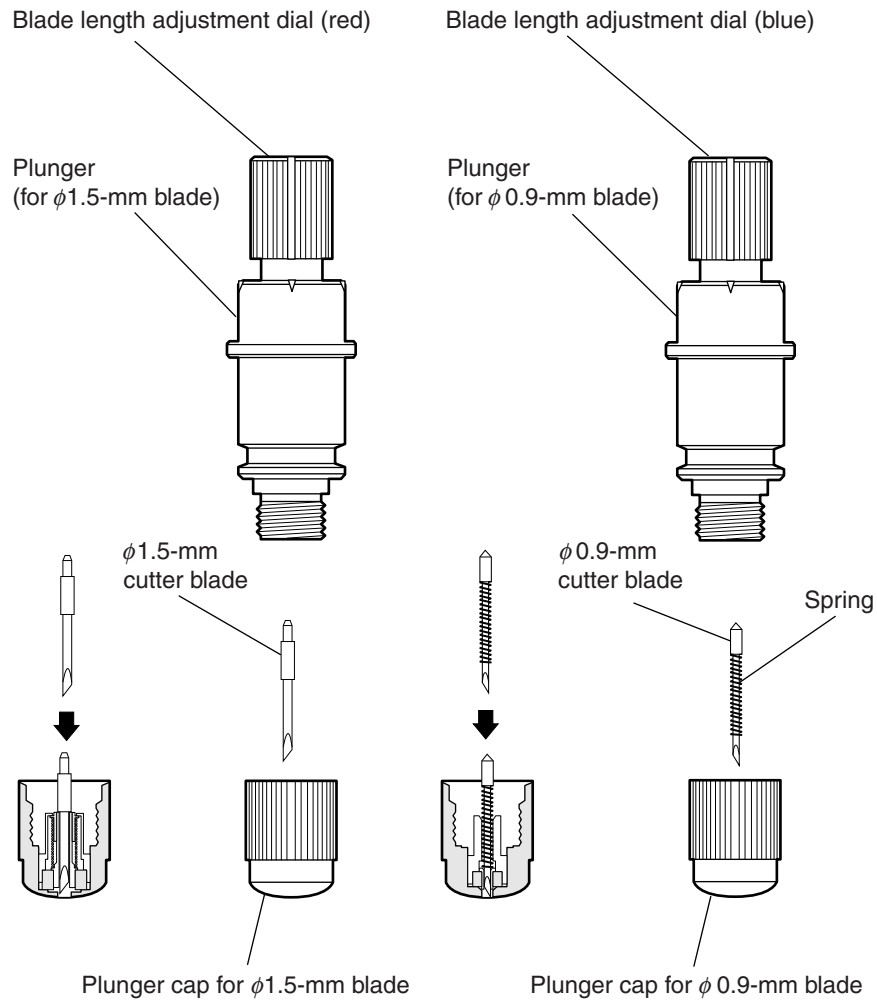

- (1) Turn the blade length adjustment dial to retract the blade inside the plunger.
- (2) Turn the plunger cap in the counter-clockwise direction to unscrew it from the plunger.
- (3) Remove the blade inside the plunger cap.
- (4) Take a new blade and insert it into the opening in the plunger cap.
- (5) With the blade inserted into the plunger cap, attach the plunger from above.

2.4 Adjusting the Blade Length



CAUTION



When handling cutter blades, be careful to avoid cutting your fingers or other parts of your body.

Make sure that the blade length is suitable for the thickness of the medium being used. If the blade is extended too far, the writing panel and the blade itself may be damaged.

■ Adjusting the Blade Length

- (1) Before adjusting the blade length, align the blade tip with the tip of the cutter plunger by turning the blade adjustment knob in the **B** direction (see the figure below).

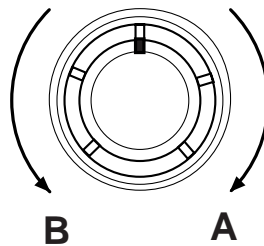

- (2) Next, extend the blade tip to the length suitable for the medium to be used by turning the blade adjustment length in the **A** direction.

Observe the scale on the plunger cap to determine how far to move the blade.

When the knob is turned the distance of one scale unit, the blade moves 0.1 mm. When it is given one full turn, the blade moves 0.5 mm.

To extend the blade, turn the knob in the **A** direction.

To retract the blade, turn it in the **B** direction.

■ Obtaining the Correct Blade Length

Assuming that the film thickness is " t ", the blade length " l " should be equal to or slightly greater than " t ". Make sure that " l " is never greater than the combined thickness of the film and its backing sheet.

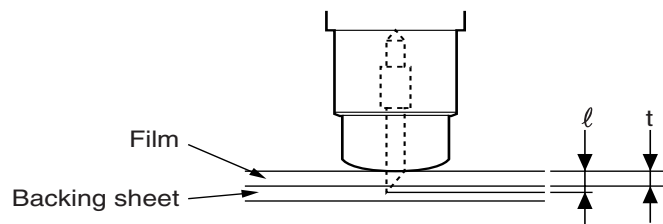

If the film thickness cannot be accurately determined, adjust the blade length by gradually increasing it until only traces of the blade appear on the backing sheet when a cutting test is executed.

3. PREPARING FOR A CUTTING OPERATION

This chapter provides instructions on using the control panel, loading a medium, setting the cutting conditions, and so forth.

3.1 Control Panel

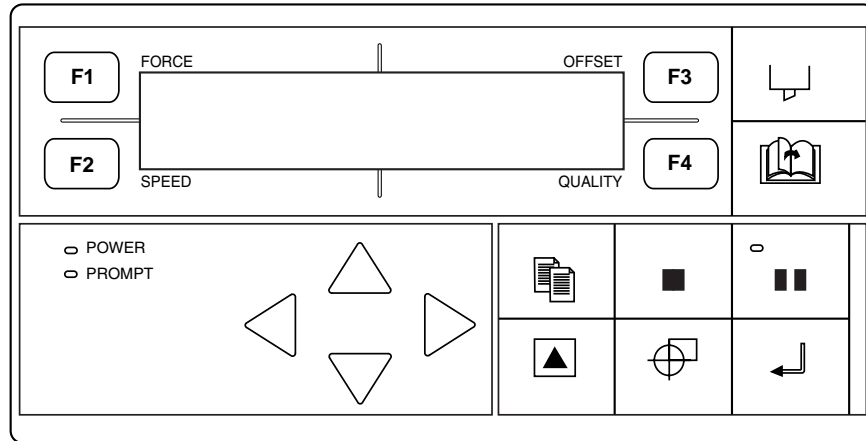

■ Indicator Lamps

- POWER The POWER lamp remains lit (green) while the plotter is on.
- PROMPT The PROMPT lamp lights (red) when the plotter receives data that will cause the pen carriage to move outside the effective cutting area.

■ Function Keys

The four function keys **F1** through **F4** are used to select a menu or to select a function on a displayed menu.

- F1** Press the **F1** key to select a function during Menu mode, to select Cutter Conditions 1 during Online status, or to change the FORCE setting after the **CONDITIONS** key has been pressed.
- F2** Press the **F2** key to select a function during Menu mode, to select Cutter Conditions 2 during Online status, or to change the SPEED setting after the **CONDITIONS** key has been pressed.
- F3** Press the **F3** key to select a function during Menu mode, to select Cutter Conditions 3 during Online status, or to change the OFFSET setting after the **CONDITIONS** key has been pressed.
- F4** Press the **F4** key to select a function during Menu mode, to select Cutter Conditions 4 during Online status, or to change the QUALITY setting after the **CONDITIONS** key has been pressed.

■ POSITION Keys

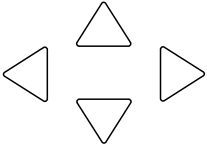

These **POSITION** keys function differently according to the plotter's operating status. They are used to change a setting on a displayed menu during Menu mode, but are used to move the pen carriage at all other times.

When a key is first initially pressed, the pen carriage moves slowly. When you continue to hold down the key, the pen carriage starts moving more quickly.

■ Menu Keys

■ ■ **PAUSE** key: Press this key to enter Menu mode and light its green lamp. Press it again to cancel Menu mode and turn off the lamp. Press this key when you wish to proceed to set a function. If the plotter receives data after this key is pressed, it will temporarily store the data in its data buffer.



..... **ENTER** key: Press this key to register the selected setting when specifying a function. In Pause status, you can reset the plotter by concurrently pressing the ENTER and ORIGIN keys.



..... **ORIGIN** key: Used to change the position of the coordinate system's origin point. When the automatic detection of registration marks is enabled, press this key to initiate automatic detection.



..... **COPY** key: Used to repeat the cutting operation defined by the data in the plotter's buffer.



..... **CONDITIONS** key: Press this key to change any of the cutting conditions appearing on the plotter's display panel.



..... **TEST** key: Press this key to run a test to check whether the currently selected cutting conditions are suitable for the medium loaded.



..... **NEXT PAGE** key: Press this key during Menu mode to proceed to the next menu page.



..... **CANCEL/VIEW** key: During a cutting operation, press this key to immediately stop cutting. While the Ready message is being shown on the plotter's display panel, press this key to move the pen carriage to the outer limit of the maximum cutting/plotting area. To return the pen carriage to its original position, press this key again.

3.2 The Tree Structure of Menus

■ In Menu mode

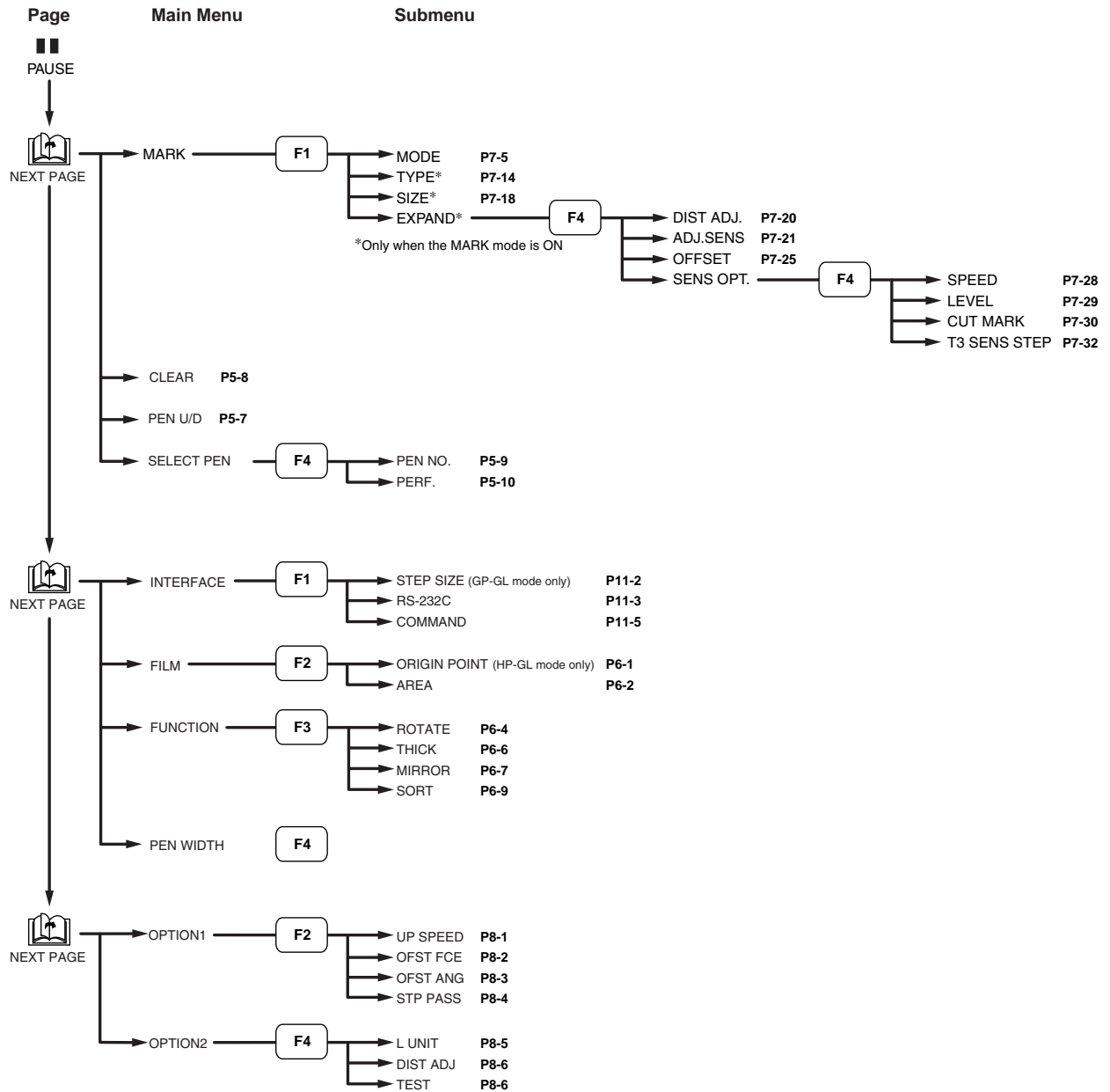

3.3 Connecting Your Plotter to a Computer

Your plotter is connected to a computer using an interface cable. This connection can be made by connecting the cable either to the computer's printer (Centronics-compatible parallel) port or to its serial (RS-232C) port. Select the port to be used in accordance with the specifications of the application software being used and the available communications port(s) of your computer.

Depending on the port used, connect the plotter using either a Centronics-compatible cable or an RS-232C serial cable. Obtain the Graphtec-designated interface cable (sold separately) that is compatible with the computer model to be connected to the plotter.

Procedure

- (1) Make sure that the plotter's Power switch is turned off (the switch's "O" side should be pressed down). Also check that the computer is turned off.
- (2) Connect one end of the interface cable to the plotter's interface connector and its other end to the computer's port. The cable's connectors are designed to be connected in a specific orientation, so be sure that each of the cable's connectors is correctly inserted into its corresponding connector on the plotter and on the computer.

Connection via the RS-232C Serial Interface

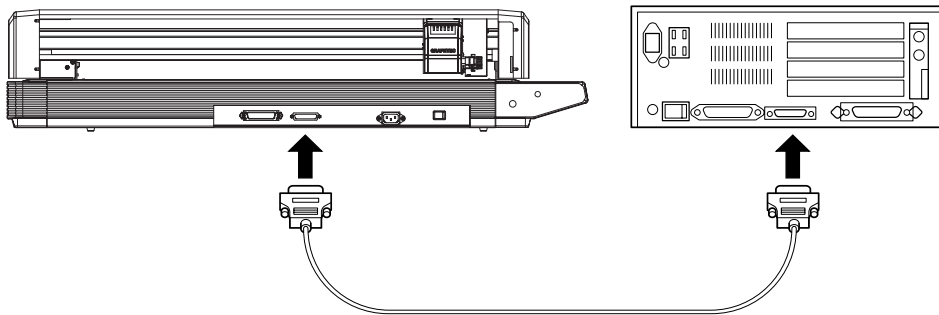

Connection via the Centronics-Compatible Parallel Interface

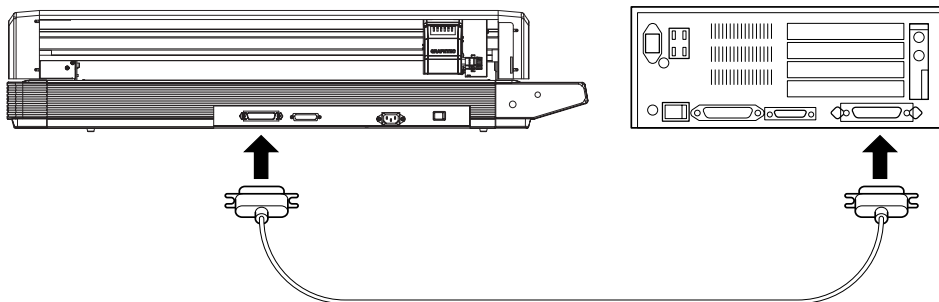

3.4 Turning on the Plotter and Initialization

- (1) Make sure that the plotter is turned off (the “○” side of the POWER switch is depressed).
- (2) Connect one end of the power cable provided to an electrical socket of the rated supply voltage then connect the other end to the plotter’s AC line inlet.

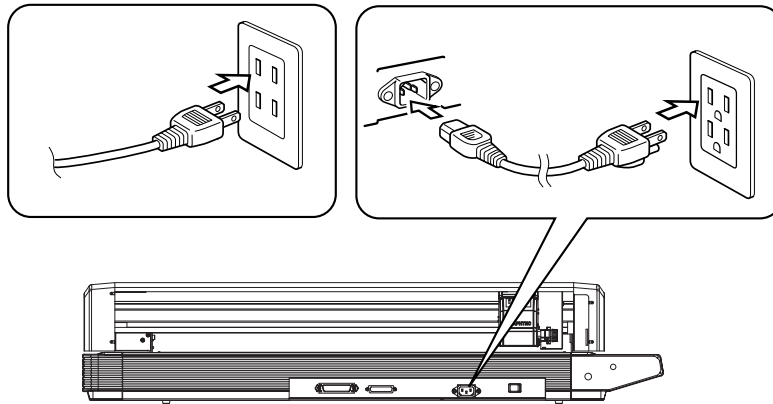

WARNING

Make sure that the plotter is grounded.

- (3) After checking that both ends of the plotter’s power cable are securely connected, turn on the plotter by pressing the “I” side of the POWER switch.
The control panel’s POWER lamp (green) lights and a memory check is performed.
- (4) The Y bar and pen carriage move in the sequence shown in the figure below.
- (5) When the pen carriage stops at the origin point, the plotter is initialized. You are now ready to load the cutting or plotting medium.

NOTE

After the pen carriage returns to the origin point in step 3, it moves out at a 45° angle and then returns to the origin point twice in steps 4 through 7. This is to detect the friction coefficients of the plotter mechanisms.

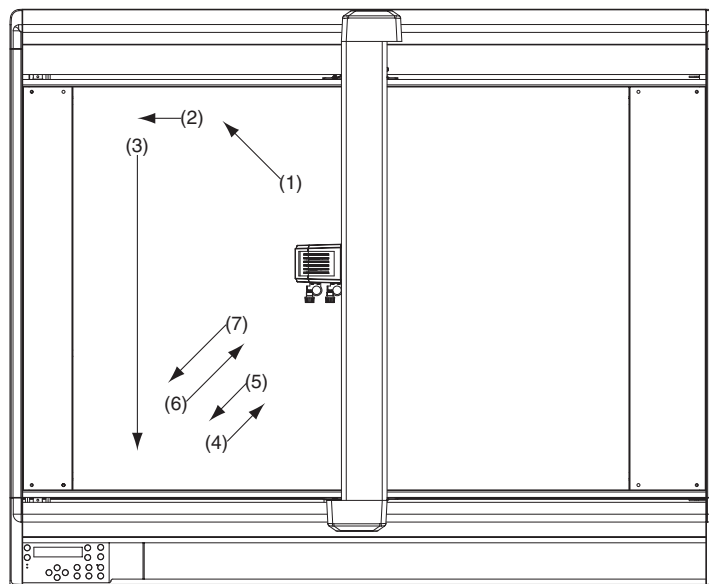

3.5 Securing a Medium

NOTE

- If air enters between the plotter's writing panel and the medium when loading the medium, smooth out the air before cutting to ensure that the medium is being firmly secured to the writing panel.
- When loading a medium that cannot be completely secured using the normal procedure described below, reinforce the adhesion by using tape or similar means to secure the medium's four corners.

Procedure

- (1) To make the medium easier to secure, move the pen carriage out of the way by pressing the **CANCEL/VIEW** key which moves the pen carriage to the upper right.

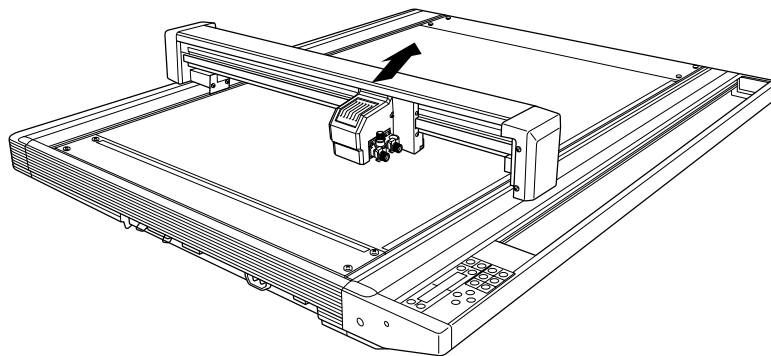
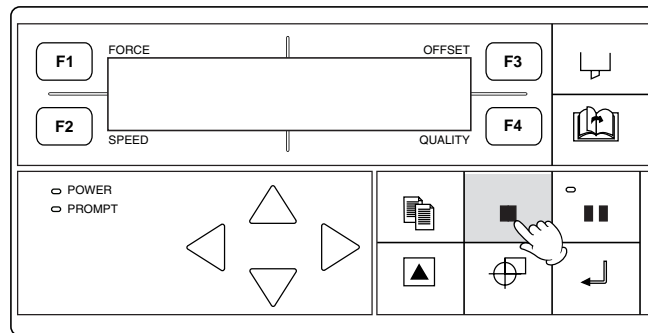

- (2) Secure the medium to the writing panel by using tape or its equivalent to tape down the edges of the medium.
- (3) Return the pen carriage to its original position by pressing the  key once more.

CAUTION

If an edge of the loaded medium comes loose, secure it with drafting tape or a similar means. The cutter blade or pen will break if its tip gets caught on a loose edge of the medium.

4. SPECIFYING THE PEN CONDITIONS

In preparation for starting a cutting operation, this chapter provides instructions on achieving optimum cutting conditions by specifying the cutter plunger's blade type as well as the cutting FORCE, cutting SPEED, cutter OFFSET, and cutting QUALITY settings.

The cutter plunger conditions for cutting media consists of the following five elements.

- (1) **Extended length of the cutter blade:** See the table below to adjust the extended length of the cutter blade to suit the thickness of the medium being used. For instructions, see Section 2.4, "Adjusting the Blade Length."
- (2) **Cutting FORCE:** Specify the FORCE setting based on the reference FORCE values listed in the table below.
- (3) **Cutting SPEED:** Specify the SPEED setting based on the reference SPEED values listed in the table below.
- (4) **Cutter OFFSET:** Specify the OFFSET setting based on the reference values listed in the table below.
- (5) **Cutting QUALITY:** Specify the QUALITY setting based on the reference values listed in the table below.

4.1 The Cutter Plunger's Conditions

Optimum Cutting Conditions by Media Type

Medium	Thickness (mm)	Blade used	FORCE	SPEED	QUALITY
Film for outdoor signs	0.05 to 0.08	CB09UA	10 to 14	30 or less	2 to 3
Decorative film	0.08 to 0.1	CB09UA	14 to 17	30 or less	2 to 3
Transparent or semi-transparent film	0.08 to 0.1	CB09UA	14 to 20	30 or less	2 to 3
Reflective film	0.08 to 0.1	CB09UA	14 to 20	30 or less	2 to 3
Fluorescent film	0.20 to 0.25	CB09UA, CB15U	20 to 24	10 to 20	2 to 3
Rubber for sandblasting	0.5 to 1.5	CB15U-K30	17 to 36	10 to 20	1 to 3
Thick paper	0.3 to 0.5	CB15U	28 to 40	10 to 20	1 to 2
Compressed styrofoam	0.8	CB15U-K30	37 to 42	10 to 20	1 to 2
High-luminance reflective film	0.25 to 0.3	CB15UA	23 to 24	5 to 25	1

Blade Part Nos., Displayed Blade Types, and OFFSET Values

Blade material	Blade's part no.	Display indication		Specifiable range	Default OFFSET
		Blade type	Displayed OFFSET		
Supersteel blades	CB09UA	09U	0	±5	17
	CB15U	15U	0	±5	28
	CB15U-K30	15U-K30	0	±5	28
Ceramic blade	CB15-10C	15-10C	0	±5	18
Sapphire blade	CB15-05S	15-05S	0	±5	9
Other		OTHER	1	1 to 45	1
Plotting pen		PEN	None	None	0
Creasing/scoring tool		CREASER	None	None	0

When a blade type has been selected, the default OFFSET value can be adjusted within a ± 5 range.
 Select OTHER when you will use a hard-to-cut medium that requires an OFFSET setting that is not listed under any of the blade types.
 Select PEN for a plotting pen.
 Select CREASER for the creasing/scoring tool.

Reference Values for Plotting Conditions

Pen type	FORCE	SPEED	QUALITY
Water-based ballpoint pen	20 to 23	40	2 to 3
Oil-based ballpoint pen	18 to 23	40	2 to 3

To avoid unnecessary wear on the pen's tip, specify the FORCE value to its lowest permissible setting. When specifying the SPEED value, check that the plotted results are not too faint or otherwise unsatisfactory.

NOTE

- Raising the SPEED and QUALITY settings results in a coarser finish but shortens the overall cutting/plotting time.
- Lowering the SPEED and QUALITY settings results in a finer finish but lengthens the overall cutting/plotting time.

4.2 Selecting a Set of Cutting Conditions

Four different sets of user-defined cutting conditions can be registered in the plotter's memory as COND Nos. 1 through 4. To specify a set of cutting conditions, you must first select the destination COND No. By selecting a different COND No., you can easily switch between pre-defined cutting conditions for four types of media.

Procedure

- (1) Press a function key (**F1** , **F2** , **F3** , or **F4**) to select a pre-defined set of cutting conditions of the corresponding number.
- (2) The selected set of cutting conditions are loaded to the plotter and become the currently selected cutting conditions.

4.3 Specifying the Cutting Conditions

This section describes how to specify the cutter plunger's blade type and its cutting FORCE, cutting SPEED, cutter OFFSET, and cutting QUALITY parameters.

- Blade Type and OFFSET Page 4-4
- CREASER Page 4-5
- Cutting FORCE and Pen FORCE (Creasing FORCE) Page 4-7
- SPEED Page 4-8
- QUALITY Page 4-9
- Cutting Conditions in THICK MODE Page 4-10

NOTE 

Before specifying the cutting conditions, first perform the setting procedure described in Section 5.6, "Specifying the Pen Conditions."

4.3.1 Display When the CONDITIONS Key is Pressed

■ For cutting/pen/creasing

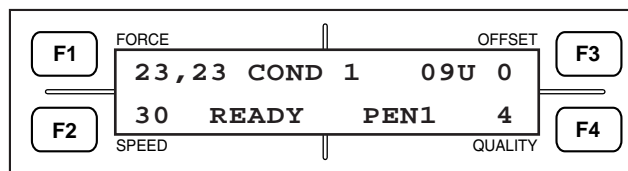

When the  CONDITIONS key is pressed

* The X/Y directions can be set for cutting/creasing.

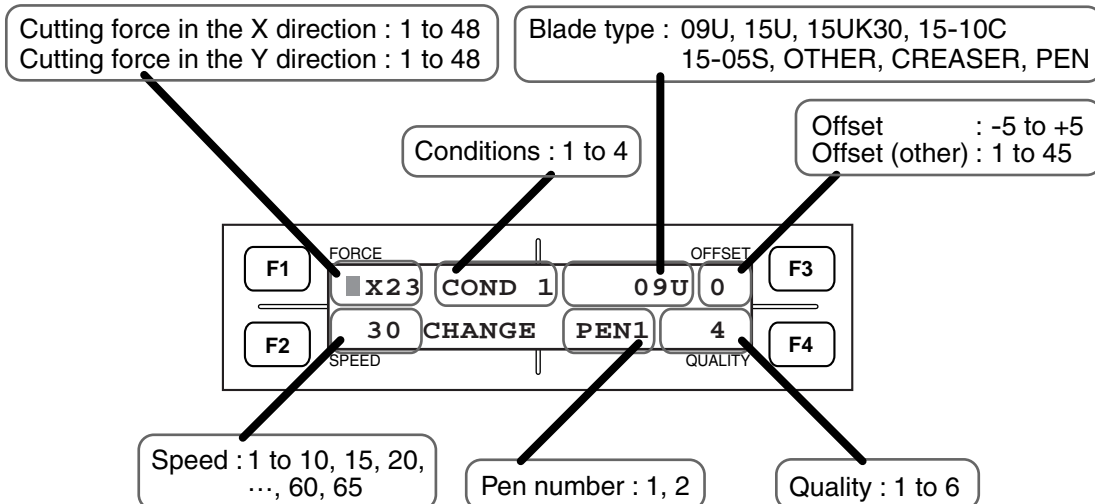

4.3.2 Setting the Blade Type and OFFSET

To set the blade type, select the cutter blade (or pen or creasing/scoring tool) to be used. If PEN is selected, a plotting pen can be used. When CREASER is selected, the creasing/scoring tool can be used. Select the name of the actual cutter blade to be used, or OTHER. The cutter blade can now be used.



The OFFSET parameter lets you specify a corrective cutter offset value when required by the blade type being used.

Because the tip of the blade mounted in the cutter pen's plunger is not positioned along the center line of the pen, the tip's offset from the pen's center must be corrected by setting the OFFSET parameter. With this plotter, the optimum OFFSET value for each blade type has been registered in advance and is automatically selected when a blade type is specified. In addition, fine adjustment of the pre-registered OFFSET value for each blade type is possible within a ± 5 range.



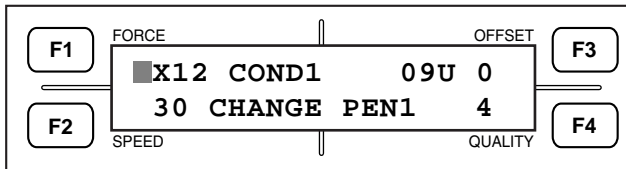

Setting Procedure

- (1) Press a function key from **F1** to **F4** to select the COND No. of the cutting conditions to be edited.
- (2) Press the  CONDITIONS key to display the menu below for specifying the cutting conditions.

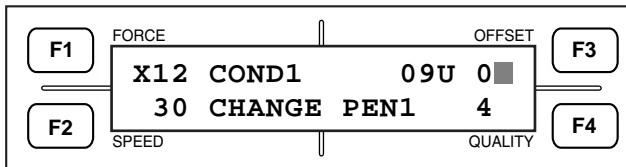

- (3) Press the **F3** (OFFSET) key to move the  blinking cursor to the upper right position as shown in the following figure. In this status, the blade type can be changed by pressing the  or  POSITION key. Select the blade type to match the currently mounted blade.



- (4) If the pen type setting is a cutter blade, press the  or  POSITION key to finely adjust the OFFSET value for that blade type within a ± 5 range.
- (5) When the displayed conditions are satisfactory, press the  ENTER key. To exit this setting operation without registering your new setting(s), press the  NEXT PAGE key before pressing the ENTER key.

When CREASER has been selected for the blade type, press the  ENTER key. The CREASER setup menu will appear. Refer to "Setting the CREASER" in the next section.

4.3.3 Setting the CREASER



In CREASER settings, the creasing mode, spacing in the creasing mode, and the start position of creasing can all be set.

Setting Procedure

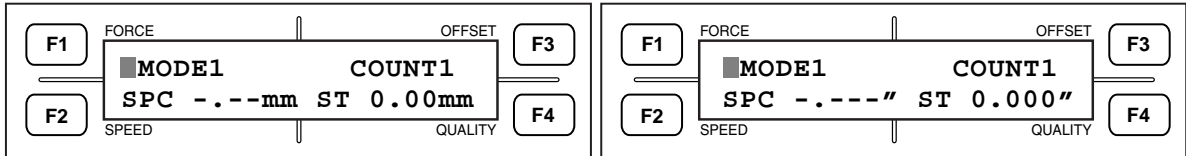
- (1) If CREASER is selected and the  ENTER key is pressed as specified in “Setting the Blade Type and OFFSET” above, the menu shown below will appear.



Setting the creasing mode

Press the  key to move the  blinking cursor to the display position shown below.

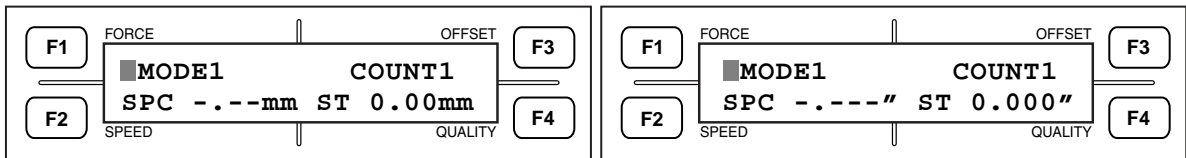

Set the creasing mode

Data (actual data)

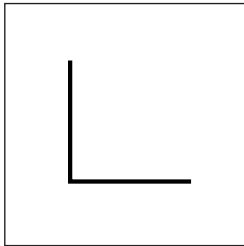

Mode 1 (crease one line)

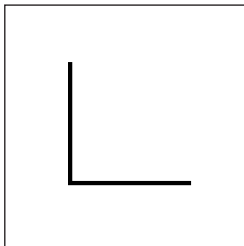

Crease lines at the same position as the actual data

Mode 2 (crease two lines)

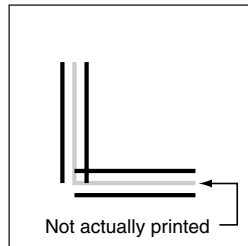

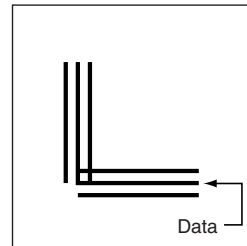

Crease lines at positions either side of the actual data

Mode 3 (crease three lines)



Crease lines at the same position as and either side of the actual data

The displayed values are the currently set values. Press the  or  POSITION key to change the creasing mode.

NOTE

The use of mode 2 or 3 allows thick media to be bent easily.

Setting the spacing

Press the **F2** key to move the █ blinking cursor to the position shown below.

* For creasing mode 1, the █ blinking cursor does not move. This operation is effective in modes 2 and 3.



At this display, set the spacing for creasing.

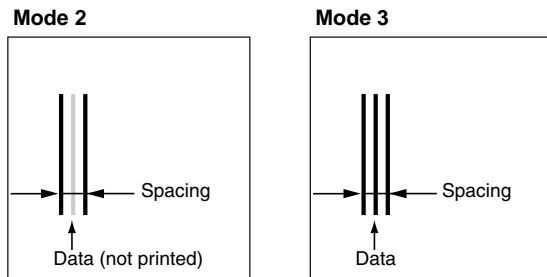

The displayed values are the currently set values. Press the **◀** or **▶** POSITION key to move the █ blinking cursor, then press the **▲** or **▼** POSITION key to change the value. The value can be set in the range of 0 to 9.99 mm (0 to 0.999”).

Setting the count

Press the **F3** key to move the █ blinking cursor to the position shown below.

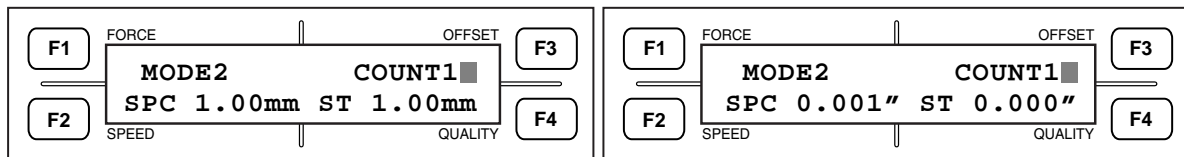

At this display, set the creasing count.

This specifies how many times creasing should reciprocate for each line segment. The displayed values are the currently set values. Press the **▲** or **▼** POSITION key to change the count. The count can be set in the range of 0 to 9 (times).

CAUTION

The creasing count represents the number of times creasing reciprocates. If the count is set to 0, creasing does not reciprocate and is completed by performing creasing in one direction.



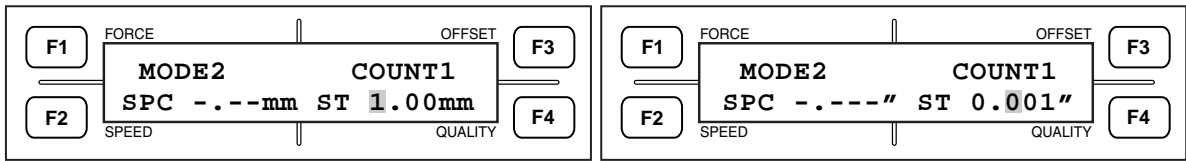

Setting the start position

Press the **F4** key to move the  to the position shown below.





At this display, set the position at which creasing starts.

The value set here is the length by which the start position of the creased line is to be moved inside.

The displayed values are the currently set values. Press the  or  POSITION key to move the . Then press the  or  POSITION key to change the value.

The value can be set in the range of 0 to 9.99 mm (0 to 0.999").

- (2) When the displayed conditions are satisfactory, press the  ENTER key. To exit this setting operation without registering your new setting(s), press the  NEXT PAGE key before pressing the ENTER key. To set the blade type, choose the cutter blade (or pen or creasing/scoring tool) to be used.



CAUTION

For short line-segment data, setting a large value for Start may make the plotter unable to plot.

4.3.4 Setting the Cutting FORCE and Pen FORCE (Creasing FORCE)

The FORCE parameter is used to specify the cutting force that is applied during cutting, the pen force that is applied during plotting, or the creasing/scoring-tool force that is applied during creasing. Set the appropriate values for this parameter based on the type of media used and the pen conditions stipulated for each pen type.

NOTE

When cardboard or microflute is cut, the force required for cutting varies depending on the moire direction of the media.

Setting Procedure

- (1) Press a function key from **F1** to **F4** to select the COND No. of the cutting conditions to be edited.
- (2) Press the  CONDITIONS key to display the menu below for specifying the cutting conditions.

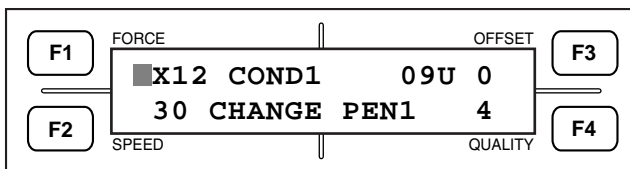

* If the selected blade type is Pen, X/Y are not displayed.

- (3) Press the **F1** (FORCE) key to move the █ blinking cursor to the upper left position as shown in the menu below.

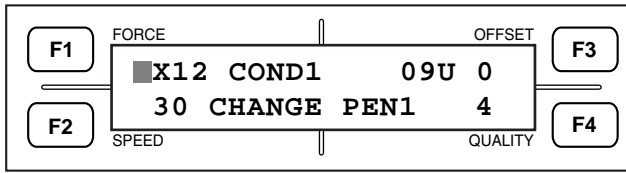

* If the selected blade type is Pen, X/Y are not displayed.

- (4) In this state, press the \triangleleft or \triangleright POSITION key to switch between the X and Y directions. In addition, while the desired direction is displayed, press the \triangle or ∇ POSITION key to change the cutting force or pen force.

The cutting and pen forces can be set in the range of 1 to 48 for both the X and Y directions.

- (5) When the displayed conditions are satisfactory, press the \blacksquare ENTER key. To exit this setting operation without registering your new setting(s), press the \blacktriangleright NEXT PAGE key before pressing the ENTER key.

4.3.5 Setting the SPEED

The SPEED parameter is used to specify the speed that is applied during cutting or plotting or the speed that is applied during creasing/scoring. Set the appropriate values for this parameter based on the type of media and the pen conditions stipulated for each pen type.

Setting Procedure

- (1) Press a function key from **F1** to **F4** to select the COND No. of the cutting conditions to be edited.
 (2) Press the \blacksquare CONDITIONS key to display the menu below for specifying the cutting conditions.

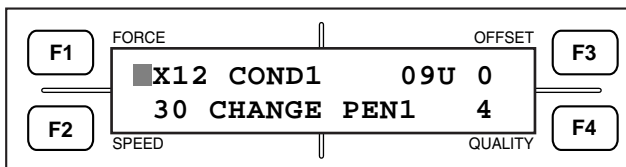

- (3) Press the **F2** (SPEED) key to move the █ blinking cursor to the lower left position as shown in the following figure.

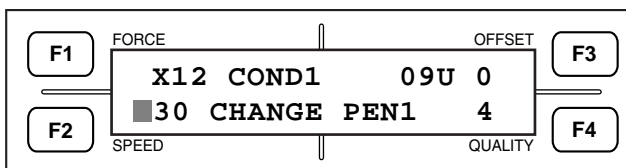

- (4) To change the SPEED setting, press the \triangle or ∇ POSITION key.
 Permissible SPEED values are: 1 through 10, 15, 20, 25, 30, 35, 40, 45, 50, 55, 60, and 65.
 (5) When the displayed conditions are satisfactory, press the \blacksquare ENTER key. To exit this setting operation without registering your new setting(s), press the \blacktriangleright NEXT PAGE key before pressing the ENTER key.

4.3.6 Setting the QUALITY

The QUALITY parameter is used to specify the acceleration that is applied during cutting or plotting or the acceleration that is applied during creasing/scoring. Set the appropriate values for this parameter based on the type of media and the pen conditions stipulated for each pen type.



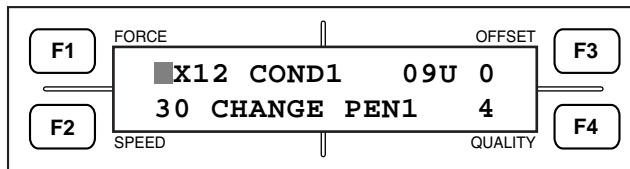

Setting Procedure

- (1) Press a function key from **F1** to **F4** to select the COND No. of the cutting conditions to be edited.
- (2) Press the  CONDITIONS key to display the menu below for specifying the cutting conditions.

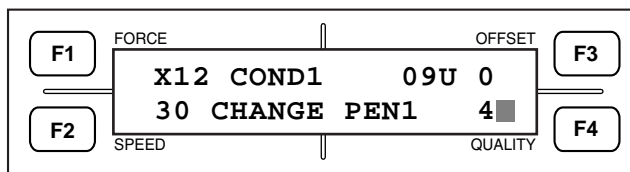

- (3) Press the **F4** (QUALITY) key to move the  blinking cursor to the lower right position as shown in the menu below.



- (4) To change the QUALITY setting, press the  or  POSITION key to specify the QUALITY setting in a range from 1 to 6. A lower value selects a slower acceleration rate which results in higher quality.
- (5) When the displayed conditions are satisfactory, press the  ENTER key. To exit this setting operation without registering your new setting(s), press the  NEXT PAGE key before pressing the ENTER key.

4.3.7 Setting Cutting Conditions in THICK MODE

Select the THICK MODE setting when you will be cutting either thick media (such as masking rubber for sandblasting or thick paper for apparel patterns) or thin but hard media (such as acrylic film).

NOTE

For more information about the THICK MODE parameter, see Section 6.4, "Enabling the THICK MODE Setting."

Setting Procedure

- (1) When the THICK MODE setting has been enabled for the currently selected COND No., the display appears as follows.

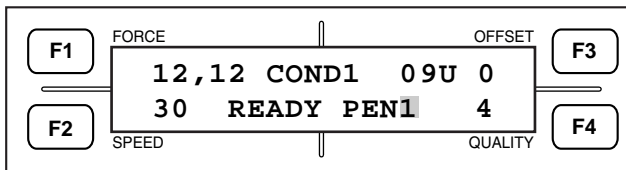

- (2) Press the  CONDITIONS key to display the menu below for specifying the cutting conditions.

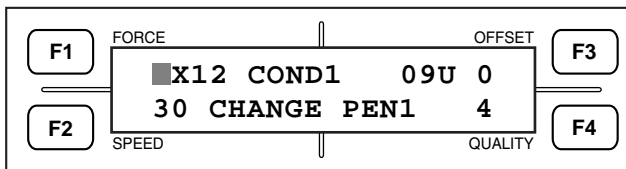

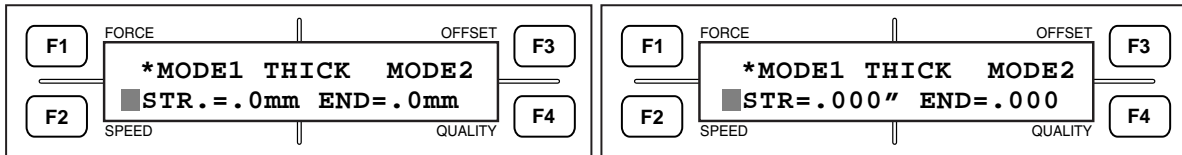

- (3) Press the  ENTER key to display the THICK MODE menu shown below.



- (4) Press the **F1** (MODE 1) or **F3** (MODE 2) key to move the asterisk symbol and select MODE 1 or 2.

MODE 1 : Overcutting is performed at the starting and end points of cutting as well as at corners with a sharp angle in order to prevent incomplete cut areas of the medium. Moreover, because the blade is moved across the medium's surface in one stroke when the cutter's blade must rotate by a wide angle, this mode allows you to cut thicker media or perform more detailed cutting than is possible in MODE 2.

MODE 2 : Overcutting is only performed at the starting and end points of cutting. Because MODE 2 performs simpler blade control of the travelling cutter blade than MODE 1, the overall cutting time is shorter.

Press the **F2** (STR.) or **F4** (END) key to move the  blinking cursor next to the STR. or END setting. In this status, press the  or  POSITION key to specify the overcut distance.

- (5) When the displayed conditions are satisfactory, press the  ENTER key. To exit this setting operation without registering your new setting(s), press the NEXT PAGE key before pressing the ENTER key.

4.4 Running a Cutting Test

After specifying the blade type, OFFSET, FORCE, and SPEED settings, run a cutting test to actually confirm the combined impact of your settings. Check how deeply the medium has been cut and the roundness of the cut corners. If the cut results are not satisfactory, specify your cutting conditions once more and then run another cutting test. Repeat these two steps until the optimum cutting conditions are achieved.

Setting Procedure

- (1) Load the medium that will actually be used for cutting.
- (2) Press a function key from **F1** to **F4** to select the target COND No.
- (3) Press the **▲** TEST key to display the TEST menu below.

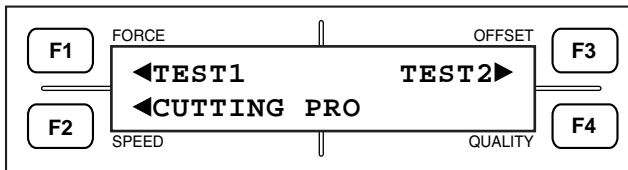

- (4) Using the **◀**, **▶**, **▲**, **▼** POSITION keys, move the carriage to the position on the medium from which you wish to start the cutting test.



CAUTION

The cutter unit will start moving as soon as the TEST function is selected, so be sure to keep your hands, hair, and face away from the moving parts.

- (5) Press the **F1** (TEST 1) key to cut a single test pattern, consisting of a triangle within a square, at the cutter pen's current position.

Press the **F3** (TEST 2) key to cut three test patterns, each consisting of a triangle within a square, at the cutter pen's current position. Among the three patterns, the first pattern is cut using the current FORCE setting minus 1, the second pattern is cut using the current FORCE setting, and the third pattern is cut using the current FORCE setting plus 1.

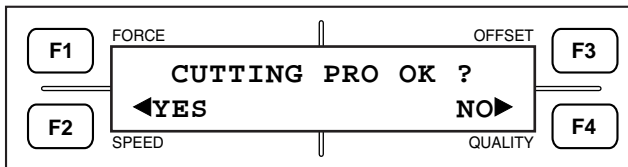

Press the **F2** (CUTTING PRO) key to display the CUTTING PRO prompt menu shown below.

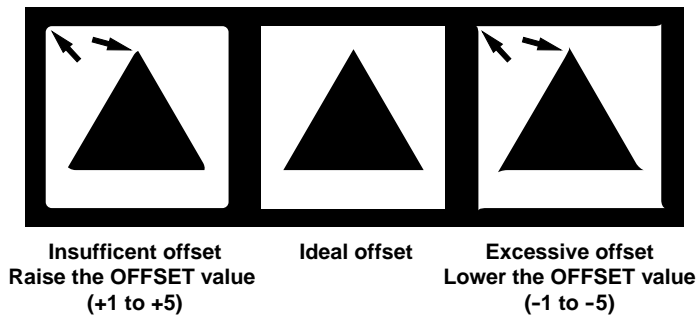

While the above menu is displayed, press the **F2** (YES) key to cut out the CUTTING PRO characters from the cutter pen's current position. To return to Step (3) without running the CUTTING PRO test, press the **F4** (NO) key.

- (6) Check the cut pattern(s). Peel off the four outside corners of the test pattern(s) that you cut by selecting TEST 1 or 2, and then look at the corners of the inner triangle. If the corners are rounded, the OFFSET setting is too low. Conversely, if the corners are too pointed, the OFFSET setting is too high.



- (7) Next, peel off the corners of the triangle(s). Ideally, only slight traces of the cutter blade should remain on the medium's base sheet. If the base sheet has been cut through, either the FORCE setting is too high or the cutter blade's tip is extended too far. If the base sheet shows only a few traces of the cutter blade, either the FORCE setting is too low or the cutter blade's tip is not sufficiently extended.
- (8) Press the  CONDITIONS key to display the menu for specifying the cutting conditions, then adjust the FORCE and OFFSET settings.
- (9) Repeat Steps (3) through (8) until you achieve satisfactory test results.
- (10) When satisfactory test results are achieved, press the  ENTER or  NEXT PAGE key to return the plotter to READY status.

4.4.1 When the Blade Type is Set to CREASER

Test Procedure

- (1) Load the medium on which creasing or scoring will actually be performed.
- (2) Press a function key from **F1** to **F4** to select the target COND No.
- (3) Press the **▲** TEST key to display the TEST menu below.

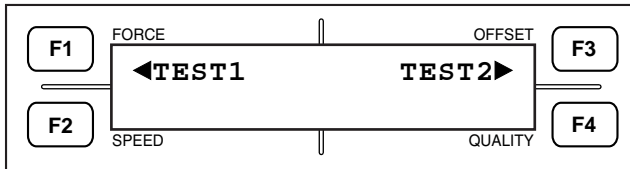

- (4) Using the **◀**, **▶**, **▲**, **▼** POSITION keys, move the carriage to the position on the medium at which you wish to start the cutting test.



CAUTION

The cutter unit will start moving as soon as the TEST function is selected, so be sure to keep your hands, hair, and face away from the moving parts.

- (5) Press the **F1** key (TEST 1) to crease one line of the creasing test pattern at the current position. Press the **F3** key (TEST 2) to crease three lines of the creasing test pattern at the current position. The three creasing test patterns are cut using different forces. The first, second, and third patterns are cut using the set cutting force (creasing force) - 1, using exactly the set cutting force (creasing force), and using the set cutting force (creasing force) + 1, respectively.
- (6) Check the creasing test patterns. For this check, inspect the status of the test patterns creased in test-1 or test-2 mode. Inspect how the test patterns are creased. If the pattern is creased in a shallow manner, the creasing force is insufficient. Conversely, if the pattern is creased deeply or in a broken manner, the creasing force is excessive.

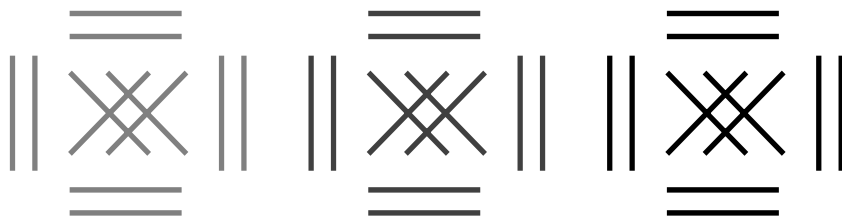

Insufficient force
Increase the cutting force
(creasing force)
(+1 to +5)

Appropriate

Excessive force
Reduce the cutting force
(creasing force)
(-1 to -5)

- (7) Press the **□** CONDITIONS key to adjust the cutting force (creasing force) on the condition setup menu.
- (8) Repeat steps (3) through (7) until the appropriate creasing is obtained.
- (9) When the appropriate creasing is obtained, press the **↵** ENTER key or **▶** NEXT PAGE key to return the plotter to READY status.

5. USING THE BASIC FUNCTIONS

This chapter explains how to use the plotter's basic functions.

5.1 Specifying the Origin Point of the Plotting Area

The starting position for a cutting operation or a plotting operation can be moved freely to another position within the mechanical plotting area.

NOTE

To use this function, the MARK setting must be off. (For more information, see Section 6.7, "Setting the MARK MODE Parameter to Print Registration Marks.")

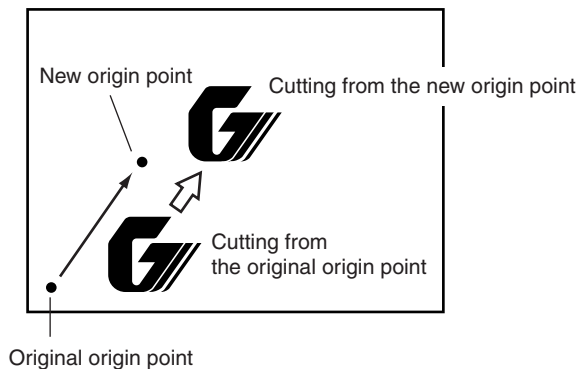

Setting Procedure

- (1) With the plotter in READY status, use the ◀, ▶, ▲, ▼ POSITION keys to move the pen carriage to the position of the new origin point.
- (2) When the ORIGIN key is pressed, a beeper will sound and the new origin point will be set at the current position of the pen carriage.

After moving the origin point, your new origin point will be initialized when you rotate the coordinate axes using the ROTATE parameter, set the MIRROR MODE setting to ON, or select or deselect the plot area.

To rotate the coordinate axes or use the MIRROR MODE with a new origin position, be sure to specify the ROTATE and MIRROR MODE parameters before specifying the origin point of the plotting area.

NOTE

The coordinate values displayed after a new origin point has been specified represent the relative distance of the current position from the new origin point.





5.2 Using the COPY function

When data used for a cutting operation is stored in the plotter's internal buffer memory, this function lets you repeatedly cut duplicates of that data.



CAUTION

- While a COPY operation is in progress, do not send new data from the computer. The existing data will be overwritten and erased by the new data.
- After completing a cutting operation, if you allow at least 10 seconds to lapse before sending the next set of data, the existing data will be cleared and any data sent after the lapse of 10 seconds or more will be saved as new cutting data that can be used in a COPY operation.
- If you send data of more than about two Mbytes, such data will exceed the maximum capacity of the internal buffer memory and thus cannot be used for a COPY operation. (You can change the size of the buffer that can be used for COPY operations by switching the ON/OFF status of the SORTING parameter and so forth.)
- While using the COPY mode, be careful not to cut the exposed area of the plotter's writing panel that is not covered by the medium.
- When receiving data that is to be cut at a position that is separated from the origin point, the copy of that data will also be cut at the same distance from the origin point. In order to cut down on wasted space, try to specify the cutting data so that it will be cut as close as possible to the origin point.
- Except when the MARK MODE setting is OFF, the plotter will enter the MARK MODE, read the registration marks, and then make a single copy.

Setting Procedure

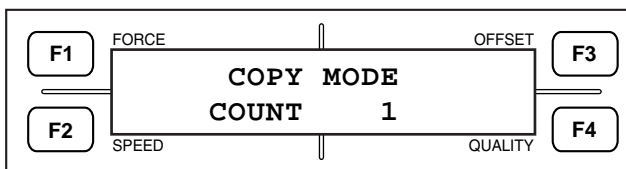

- (1) Perform a cutting operation using the target data in order to save it in the internal buffer memory.
- (2) Using the , , ,  POSITION keys, move the pen carriage to the position on the medium where you wish to make the copy.
- (3) Press the  COPY key to display the menu below.



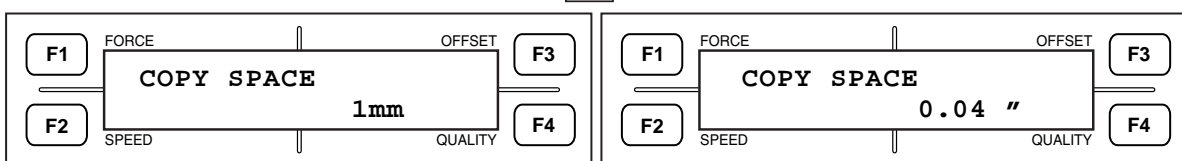

- (4) Use the ,  POSITION keys to specify the COUNT parameter which determines how many copies will be made. The COUNT parameter can be set to a numeral no higher than the number of copies that could be cut from one sheet of the currently loaded medium.
- (5) To initiate the COPY operation, press the  ENTER key.

To set the COPY SPACE parameter, press the  COPY key to display the menu below.





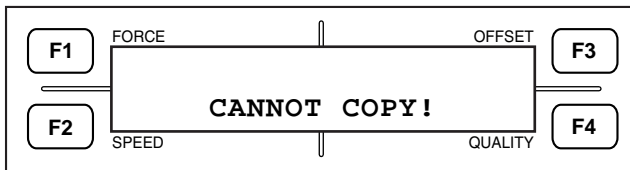

- (6) Use the ,  POSITION keys to set the COPY SPACE parameter in a range from 1 to 10 mm (0.04 to 0.40"). Your COPY SPACE setting will be retained in the plotter's internal RAM even while the plotter is turned off.

- (7) If the specified setting is satisfactory, press the  ENTER key. The “COPY” message appears and the plotter makes only the specified number of copies.

The copy data will be saved even if you replace the medium, so you can make as many copies as necessary as long as that data is not cleared from the plotter’s internal buffer memory. You can repeat the COPY operation by simply pressing the  COPY key.



- (8) If the plotter’s effective cutting area is smaller than the area required for the copy data, the “CANNOT_COPY!” message appears as shown below.

If this happens, either use the , , ,  POSITION keys to change the starting point for cutting the copy and try again, or replace the medium with a larger sheet that can accommodate the entire image to be cut.

Normally, copies will be cut as illustrated in the following example.

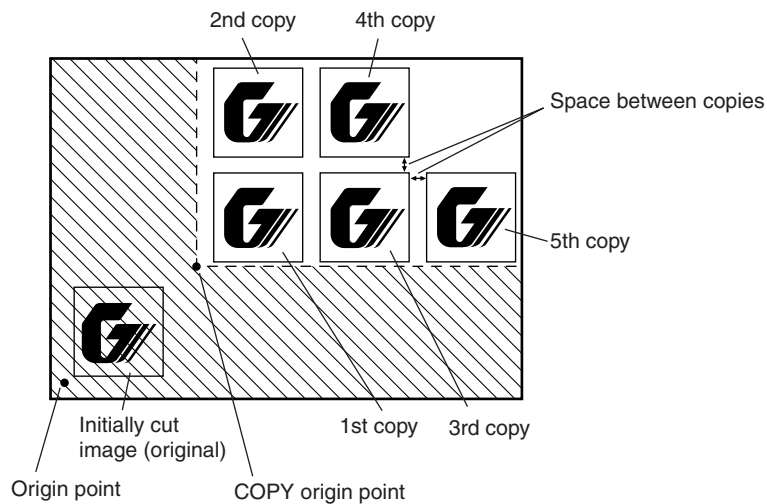

When the MIRROR MODE setting is ON, copies will be cut as illustrated in the following example.

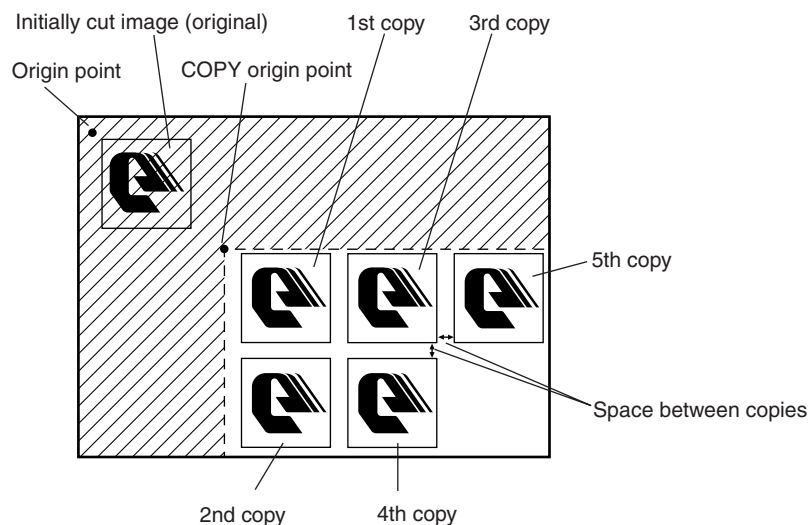

When the ROTATE parameter has been set to rotate the coordinate axes, copies will be cut as illustrated in the following example.

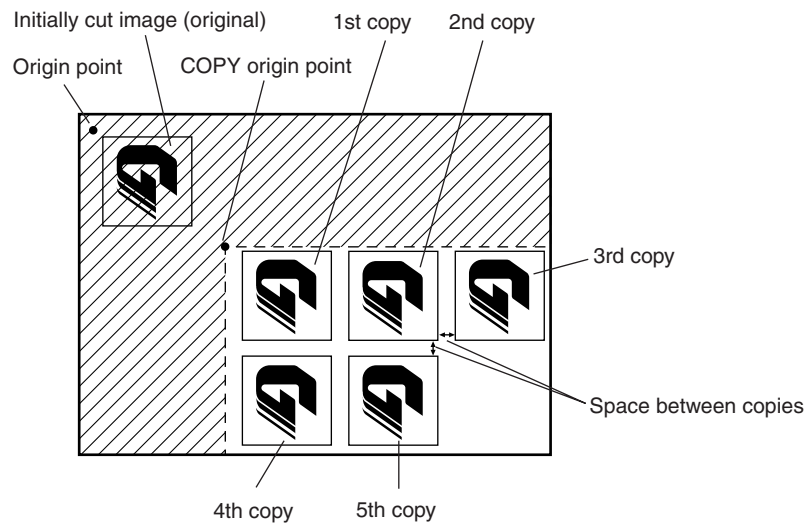

In each case, cutting will be performed in ascending order from the first copy, the second copy, and so on. Moreover, no cutting will be performed in the area indicated by hatching within each figure.

NOTE 

Your current MIRROR MODE and ROTATE settings are retained even after you change the medium.

5.3 Specifying the Corrective Values for the Pen Width

The PEN WIDTH (Interval between pens) function lets you correct any deviation between the initial cutting/plotting position of the cutter pen and plotting pen.



CAUTION

To use this function, you must first specify PEN No. 1 for COND No. 1 and PEN No. 2 for COND No. 2. (For more information, see Section 5.6, "Specifying the Pen Conditions."). Unless these PEN Nos. 1 and 2 have been respectively specified for COND Nos. 1 and 2, a prompt will appear that instructs you to do so. Mount a ballpoint pen in both Pen holder 1 and Pen holder 2.

Setting Procedure

- (1) Consecutively press the PAUSE key and NEXT PAGE key to display the menu below.

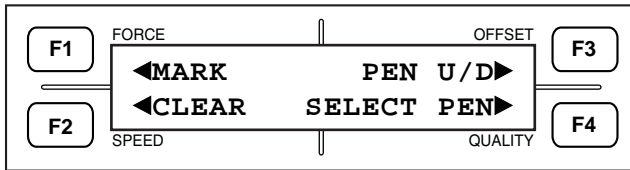

- (2) Press the NEXT PAGE key to display the menu below.



- (3) Press the **F4** (PEN WIDTH) key to display the menu below.

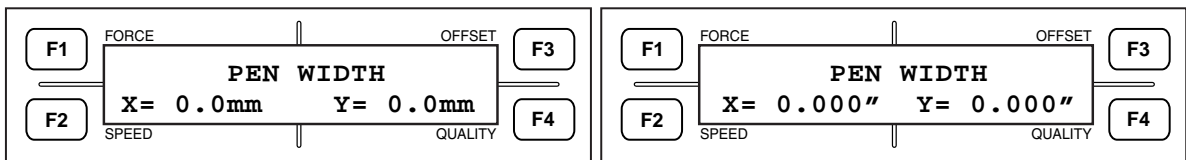

- (4) Press the TEST key to initiate plotting of the figure shown below.

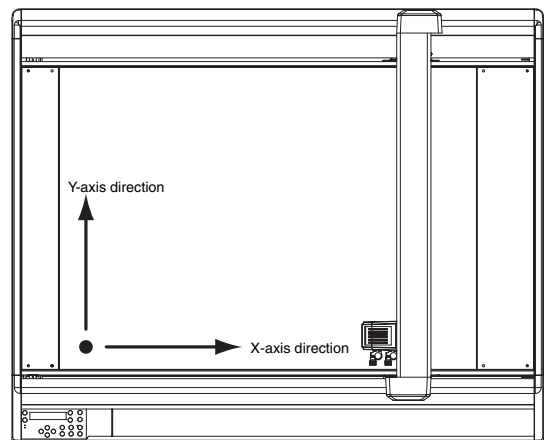
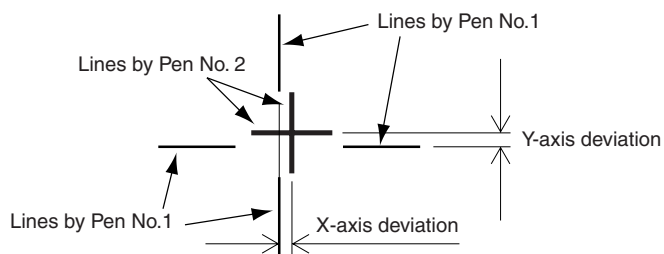

- (5) Using the lines drawn by Pen No. 2 in Pen holder 2 as reference, adjust the deviation in the lines drawn by Pen No. 1 in Pen holder 1.

- (6) To adjust the X-axis deviation, press the **F2** (X=) key and then use the \triangle and ∇ POSITION keys to change the numeric value.
To adjust the Y-axis deviation, press the **F4** (Y=) key and then use the \triangle and ∇ POSITION keys to change the numeric value.
The displayed value changes in 1-mm steps in a range from -8.0 to +8.0 (in 0.001" steps from -0.315 to +0.315).
- (7) When both corrective values are satisfactory, press the  ENTER key to register your values.

NOTE 

Your PEN WIDTH settings will be retained in the plotter's internal RAM even while the plotter is turned off.



5.4 Raising or Lowering the Pen

The PEN U/D function is used for raising or lowering the pen.

Setting Procedure

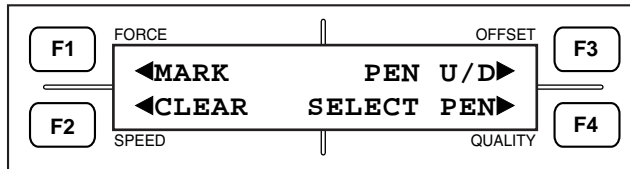
- (1) Consecutively press the  PAUSE and  NEXT PAGE keys to display the menu below.



- (2) Press the  (PEN U/D) key to lower the pen. Press the same key again to raise the pen. The pen will be either lowered or raised each time you press the  key.
- (3) Press the  PAUSE key to return the plotter to READY status.





CAUTION

When lowering or raising a pen, keep hands and other parts of the body clear of the pen holder.

5.5 Clearing the Plotter's Internal Buffer Memory

The BUFFER CLEAR function allows you to clear cutting data that has been saved in the plotter's internal buffer memory.

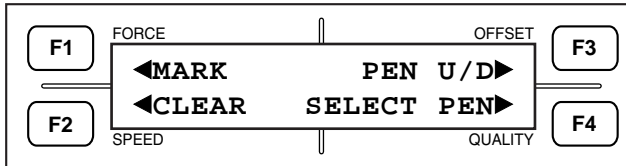

Setting Procedure

- (1) Consecutively press the  PAUSE key and  NEXT PAGE key to display the menu below.

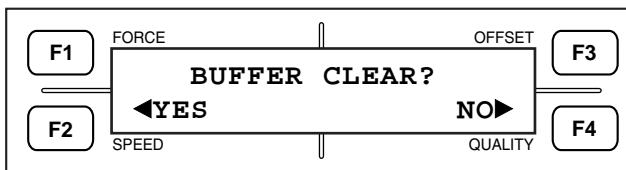

- (2) Press the  (BUFFER CLEAR) key to display the menu below.



- (3) To clear existing data in the internal buffer memory, press the  (YES) key. If you do not wish to clear the data, press the  (NO) key.
- (4) Press the  PAUSE key to return the plotter to READY status.

CAUTION

- Only use this function after the plotter has finished receiving all of the data sent from the computer.
- If you perform a BUFFER CLEAR operation while the computer is in the process of sending data, the data received in the plotter's internal buffer memory before the plotter was switched to PAUSE status will be cleared, but the plotter will output any data received after it returns to READY status from PAUSE status. In the latter case, the plotter may suddenly start operation, so be sure to keep hands and other parts of the body away from the pen holder.

If you select NO in response to the "BUFFER CLEAR?" prompt, the plotter will resume the operation which you suspended by pressing the PAUSE key.

5.6 Specifying the Pen Conditions

The SELECT PEN function allows you to assign four different sets of pen conditions (COND Nos. 1 to 4) to Pen holder 1 and Pen holder 2.

NOTE

Before using a Change Pen command, such as the “J” or “SP” command, you must first set the “SP, J COMMAND” setting to ENABLED (for instructions, see Section 9.2, “Setting the Special Functions”).

Setting Procedure

- (1) Consecutively press the  PAUSE key and  NEXT PAGE key to display the menu below.

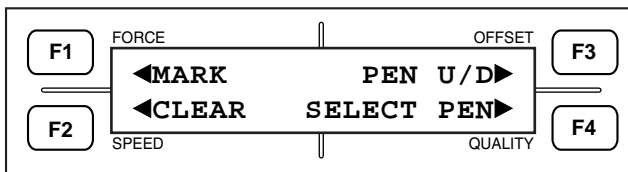



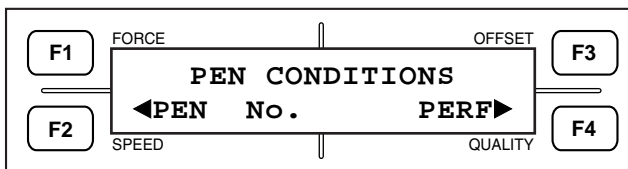

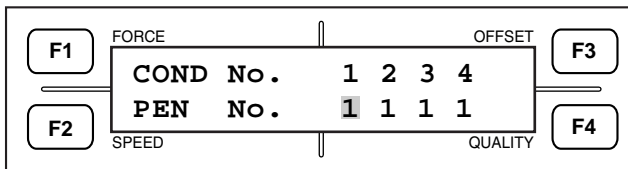

- (2) Press the **F4** (SELECT PEN) key to display the menu below.



- (3) Press the **F2** (PEN NO.) key to display the menu below.



- (4) To switch between Pen Nos. 1 and 2, press the  or  POSITION key.
 To change the position of the  cursor, press the  or  POSITION key.
 When all of the settings are satisfactory, press the  ENTER key.
- (5) Press the  PAUSE key to return the plotter to READY status.

NOTE

- Pen No. 1 is always mounted in Pen holder 1.
- Pen No. 2 is always mounted in Pen holder 2.

5.7 Setting Perforations

The PERFORATION function allows you to assign a perforating operation to any condition setting number from 1 to 4.

Setting Procedure

- (1) Press the  PAUSE key and then the  NEXT PAGE key. The menu below appears.

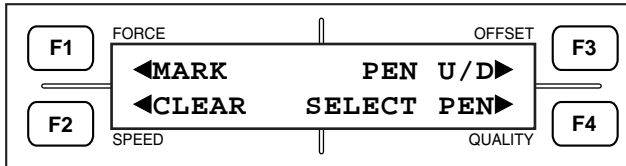

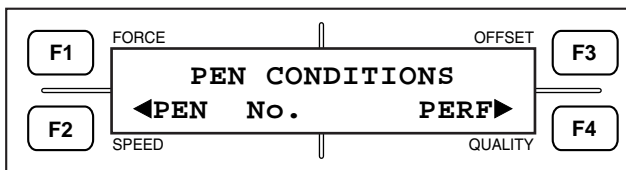

- (2) Press the  key (SELECT PEN) to display the menu below.

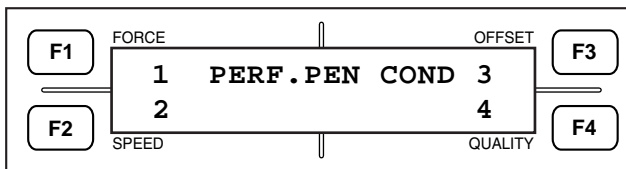

- (3) Press the  key (PERF.) to display the menu below.



- (4) The currently set value is marked with an asterisk (*). (If the asterisk is not attached, a perforating operation is not performed.)





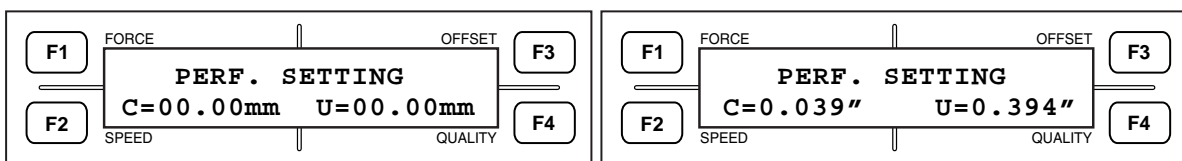

Press the  to  keys to select any condition setting number. The selected condition setting number is marked with an asterisk, indicating that it has been assigned with a perforating operation.

Press the key again to remove the asterisk.

Press the  ENTER key while any number is marked with an asterisk, and the display shown below appears.



The letter "C" indicates the length to cut (PEN DOWN) (the pen down status). The letter "U" indicates the length not to cut (PEN UP) (the pen up status).

- (5) To move the  blinking cursor, press the  or  POSITION key. To change the value, press the  or  POSITION key. When all of the settings are satisfactory, press the  ENTER key.
- (6) Press the  PAUSE key to return the plotter to READY status.

6. USING THE MAIN FUNCTIONS

This chapter explains how to use the plotter's main functions for cutting or plotting applications.

6.1 Selecting the ORIGIN POINT Position in HP-GL Mode

When the COMMAND setting is HP-GL, the ORIGIN function can be used to set the position of the origin point to either the bottom left or center of the effective cutting/plotting area. When the COMMAND setting is GP-GL, this command does not appear.

Setting Procedure

- (1) Press the  PAUSE key, then press the  NEXT PAGE key until the menu below appears.

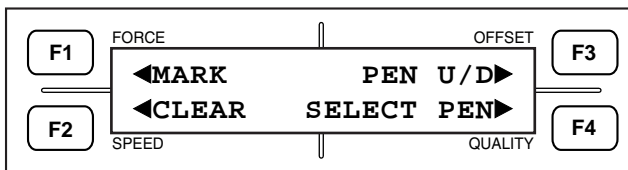

- (2) Press the  NEXT PAGE key until the menu below appears.

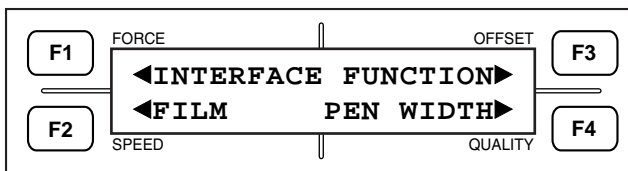



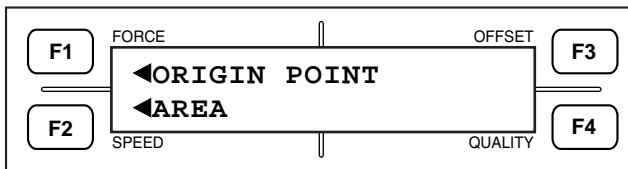

- (3) Press the  (FILM) key to display the menu below.

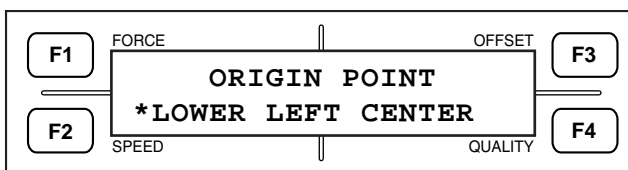

- (4) Press the  (ORIGIN POINT) key to display the menu below.



- (5) The currently selected setting is indicated by the asterisk (*) symbol.
To move the origin to the lower left of the effective cutting/plotting area, press the  (LOWER LEFT) key. To move it to the center, press the  (CENTER) key.
- (6) When the displayed setting is satisfactory, press the  ENTER key to register your setting.
- (7) Press the  PAUSE key to return the plotter to READY status.

NOTE

- Your ORIGIN POINT setting will be retained in the plotter's RAM even while the plotter is turned off.
- Even when the ORIGIN POINT setting is CENTER, the coordinate values shown on the display panel represent the relative distance of that coordinate point from the lower left corner of the effective cutting/plotting area.

6.2 Specifying the Effective Cutting/Plotting AREA

The AREA function enables you to define the effective area within which cutting or plotting will be performed by specifying the L.L. (Lower Left) and U.R. (Upper Right) corners of the desired area. Cutting or plotting will not be performed outside of the specified AREA.



CAUTION

As soon as you display this function's menu (shown in Step (4)), the pen carriage immediately moves to the current position of the origin point.

Setting Procedure

- (1) Press the PAUSE key, then press the NEXT PAGE key until the menu below appears.

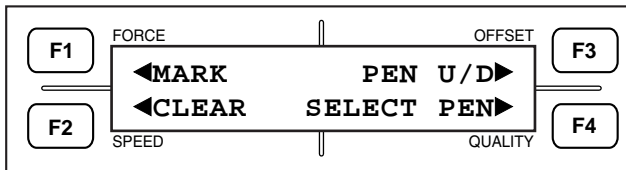

- (2) Press the NEXT PAGE key until the menu below appears.

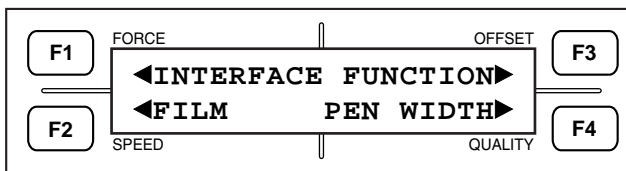

- (3) Press the (FILM) key to display the menu below.

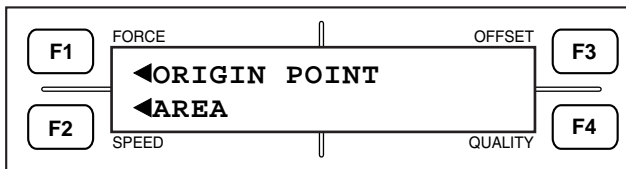

- (4) Press the (AREA) key to display the menu below.

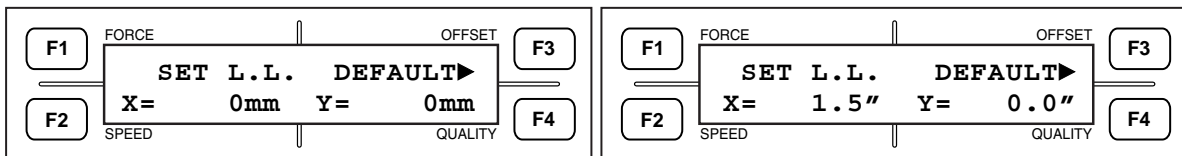

- (5) Use the , , , POSITION keys to move the pen carriage to the lower left corner of the desired area with respect to the current origin position. When you are satisfied with the position, press the ENTER key to register your L.L. setting. At such time, the coordinate values shown represent the distance from the current origin position to the current position of the pen carriage.

If the current L.L. position does not need to be changed, press the (DEFAULT) key to make the pen carriage's current position the default L.L. point.

In this case, you need not press the ENTER key.

(6) After you finish specifying the L.L. point, the following menu appears for specifying the U.R. point.

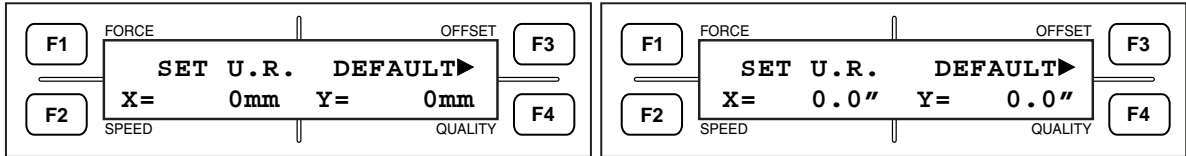

Use the ◀, ▶, ▲, ▼ POSITION keys to move the pen carriage to the upper right corner of the desired area with respect to the current origin position. When you are satisfied with the position, press the ↵ ENTER key to register your U.R. setting. At such time, the coordinate values shown represent the distance from the current origin position to the current position of the pen carriage.

If the current U.R. position does not need to be changed, press the F3 (DEFAULT) key to make the pen carriage's current position the default U.R. point.

In this case, you need not press the ↵ ENTER key.

(7) Press the PAUSE key to return the plotter to READY status.

NOTE 

- After the AREA settings have been specified, the pen carriage will move to the specified lower left point.
- The AREA function is used to set both the L.L. (Lower Left) and U.R. (Upper Right) points. When you incorrectly specify these points (by, for example, failing to allow at least 5 mm (0.2") along the X and Y axes between the upper left and lower right points or between the lower left and upper right points), the message below is displayed for several seconds. If this happens, re-specify your AREA settings correctly.

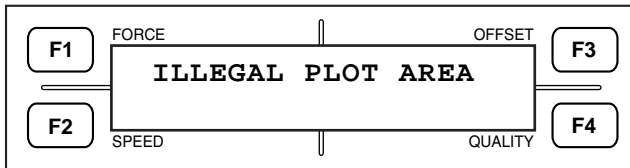

- Your AREA settings will be reset to their default values (the plotter's maximum cutting/plotting area) whenever the ROTATE or MIRROR setting is switched ON or OFF.

6.3 Enabling the ROTATE Mode to Rotate the Coordinate Axes

The ROTATE function selects the ON/OFF status of the ROTATE mode. Set the ROTATE mode to ON in order to rotate the coordinate system of an image as shown in the example below.

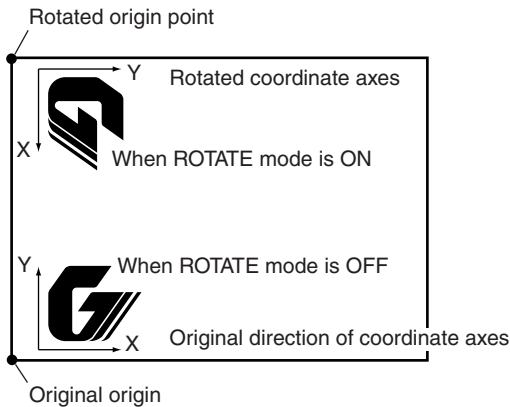

Setting Procedure

- (1) Press the PAUSE key, then press the NEXT PAGE key until the menu below appears.

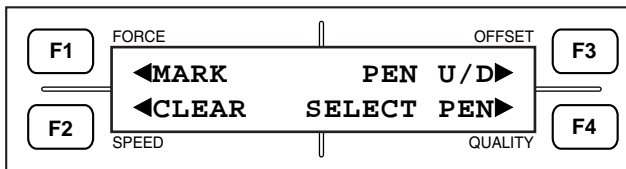

- (2) Press the NEXT PAGE key until the menu below appears.

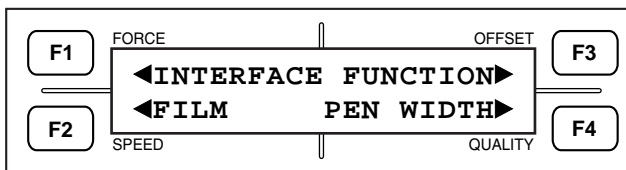

- (3) Press the **F3** (FUNCTION) key to display the menu below.

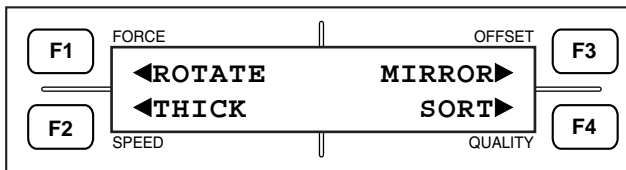

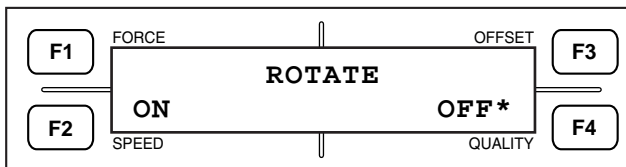

- (4) Press the **F1** (ROTATE) key to display the menu below.



- (5) The currently selected setting is indicated by the asterisk (*) symbol.

To enable the ROTATE mode, press the **F2** (ON) key.

To disable the ROTATE mode, press the **F4** (OFF) key.

- (6) When the displayed setting is satisfactory, press the  ENTER key to register your setting.
- (7) Press the  PAUSE key to return the plotter to READY status.

NOTE 

Your ROTATE setting will be retained in the plotter's RAM even while the plotter is turned off.

6.4 Specifying the THICK MODE Settings

The THICK MODE function is used to specify the THICK MODE settings. Use this function for cutting thick media (such as masking rubber for sandblasting or thick paper for apparel patterns) or thin yet stiff media (such as acrylic film).

Setting Procedure

- (1) Press the  PAUSE key, then press the  NEXT PAGE key until the menu below appears.

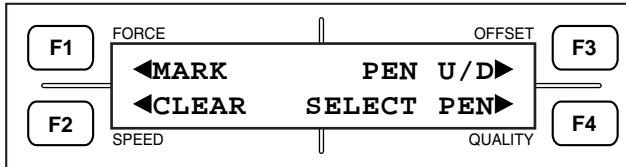

- (2) Press the  NEXT PAGE key until the menu below appears.

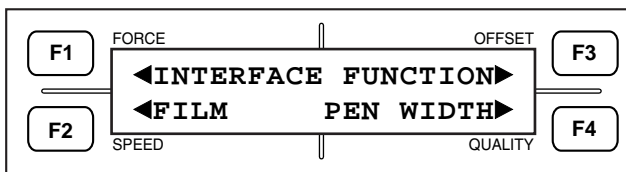



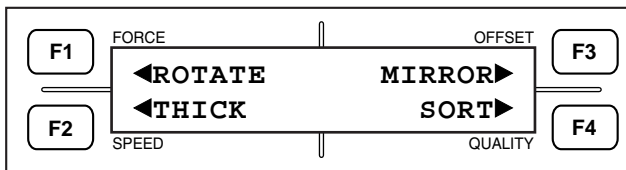

- (3) Press the  (FUNCTION) key to display the menu below.

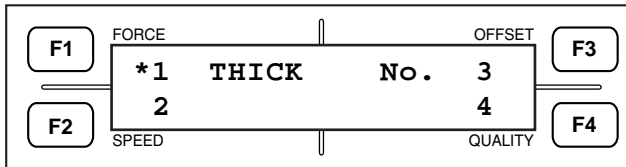

- (4) Press the  (THICK) key to display the menu below.



- (5) Press a function key ( to ) to display an asterisk (*) symbol next to the number of the set of conditions which you wish to set to THICK MODE. To remove an asterisk from a set of conditions, press the function key corresponding to the number of the target set of conditions. Up to four sets of conditions can be concurrently set to THICK MODE.
- (6) When the displayed setting is satisfactory, press the  ENTER key to register your setting.
- (7) Press the  PAUSE key to return the plotter to READY status.

When the THICK MODE is enabled for a set of conditions, a blinking square is displayed as shown below.

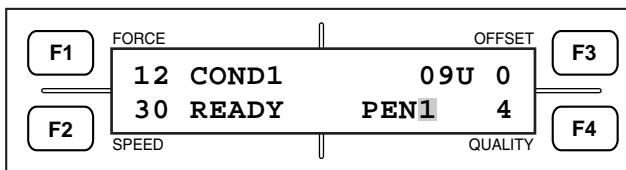

NOTE

Your THICK MODE function is only enabled for the set(s) of conditions for which it has been set.

6.5 Enabling the MIRROR Mode to Produce a Mirror Image

The MIRROR function selects the ON/OFF status of the MIRROR mode. Set the MIRROR mode to ON in order to reverse the coordinate system as shown in the example below.

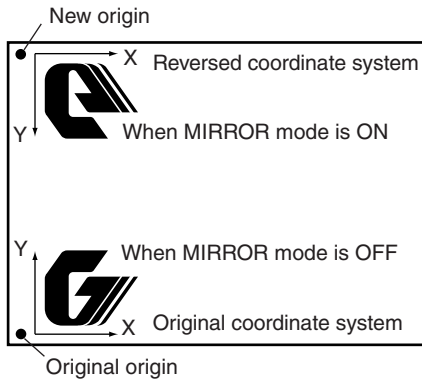

Setting Procedure

- (1) Press the PAUSE key, then press the NEXT PAGE key until the menu below appears.

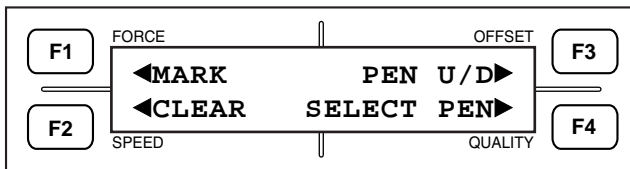

- (2) Press the NEXT PAGE key until the menu below appears.

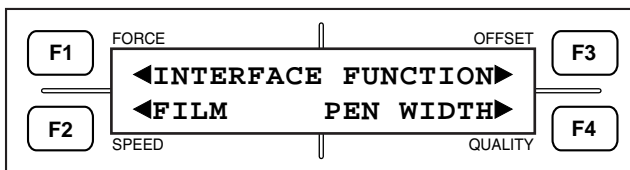

- (3) Press the (FUNCTION) key to display the menu below.

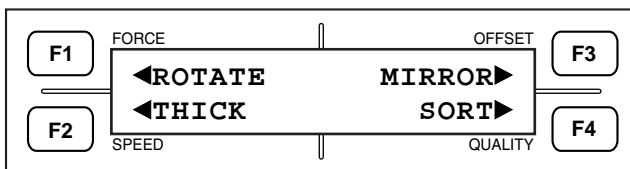

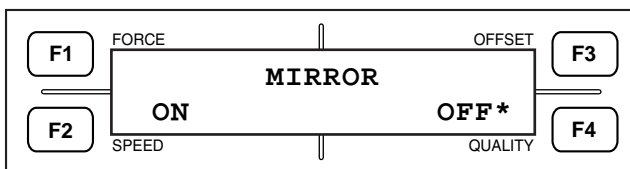

- (4) Press the (MIRROR) key to display the menu below.



- (5) The currently selected setting is indicated by the asterisk (*) symbol.

To enable the MIRROR mode, press the (ON) key.

To disable the MIRROR mode, press the (OFF) key.

- (6) When the displayed setting is satisfactory, press the  ENTER key to register your setting.
- (7) Press the  PAUSE key to return the plotter to READY status.

NOTE 

The MIRROR setting will be set to OFF when the plotter is turned off.

6.6 Specifying the Pen SORT Function

When the SORT setting is 1, the plotter stores the plotting data in its buffer memory then performs pen sorting to minimize the number of pen changes required during plotting. When the SORT setting is 2, the plotter performs pen sorting, plots the plotting data, and then performs cutting using the cutter pen last. Since the PEN SORT process accumulates data in the buffer memory before pen sorting can be done, cutting is not initiated immediately.

Setting Procedure

- (1) Press the  PAUSE key, then press the  NEXT PAGE key until the menu below appears.

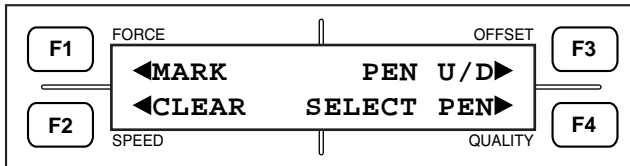

- (2) Press the  NEXT PAGE key until the menu below appears.

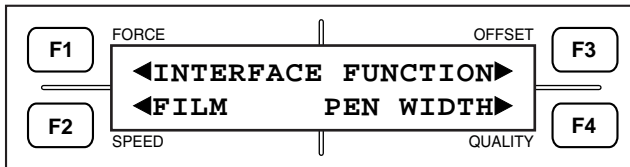

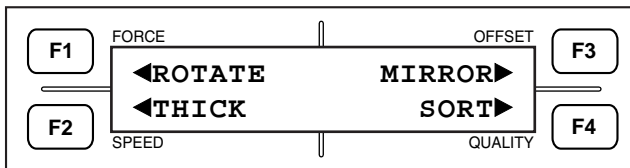

- (3) Press the  (FUNCTION) key to display the menu below.

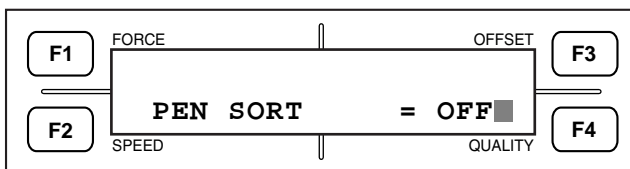

- (4) Press the  (SORT) key to display the menu below.



- (5) The currently selected setting is indicated by the  blinking cursor. Use the  and  POSITION keys to set the SORT setting to OFF, 1, or 2.

OFF : Disables the PEN SORT function.

1 : By grouping all data plotted by the same pen within the data received, the number of pen changes is minimized to shorten the time required for pen change operations.

2 : After the pen sorting and plotting operations of the PEN SORT 1 setting, the plotter finishes by performing a cutting operation using only the cutting conditions specified for a cutter pen.

- (6) When the displayed setting is satisfactory, press the  ENTER key to register your setting.

- (7) Press the  PAUSE key to return the plotter to READY status.

NOTE

Your SORT setting will be retained in the plotter's RAM even while the plotter is turned off.



CAUTION

With certain software applications, when the SORT setting is ON and the plotter receives data that takes the cutting sequence into account, the cutting sequence may be changed or the pen sorting process may take a long time to complete. With such applications, set the SORT setting to OFF.

7. USING THE REGISTRATION FUNCTION

7.1 Overview of Automatic Registration Mark Recognition

When the plotter has been set up for automatic registration mark recognition, be careful regarding the following points:

- **Registration-mark Pattern (Shape)** Page 7-1
- **Spacing of Registration Mark Patterns** Page 7-2
- **The Reading Area Required for Registration Mark Detection** Page 7-2
- **The Position of the Origin Point** Page 7-3
- **Media for which Registration Marks Cannot be Detected** Page 7-4
- **If Registration Marks Cannot be Automatically Recognized** Page 7-4
- **About the Registration Mark Mirror Patterns** Page 7-4

(1) Registration-mark Pattern (Shape)

This plotter can read (recognize) the designated registration mark patterns shown below.

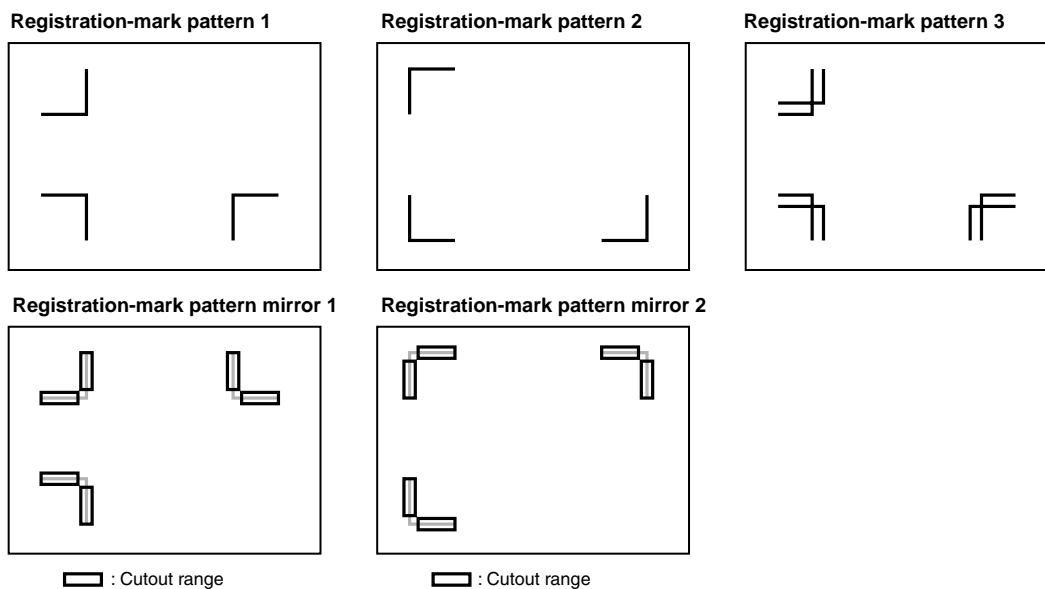

If registration-mark pattern 1 or 3 or mirror 1 or 2 is selected, the spacing between line segments can be set.

NOTE

For instructions on how to change the registration mark pattern, see Section 7.3, “Selecting the Registration MARK TYPE.”

CAUTION

- This plotter cannot recognize the pre-defined registration marks of software applications (with one exception).
- The registration marks must be generated by a software application as plotting data.
- When generating registration marks, be sure to heed the following notes on registration mark requirements.
 - The line width of registration marks must fall in a range from 0.2 to 1.0 mm.
 - The registration mark size must fall in a range from 5 to 20 mm (for details, see Section 7.4, “Specifying the Registration MARK SIZE”).
 - The registration mark pattern must conform to Pattern 1, 2 or 3.

(2) Spacing of Registration Mark Patterns

If registration mark pattern 1, 3 or mirror 1, 2 are selected, the plotter allows the spacing between line segments of registration marks to be set. Examples of the spacing between registration mark patterns are shown below.

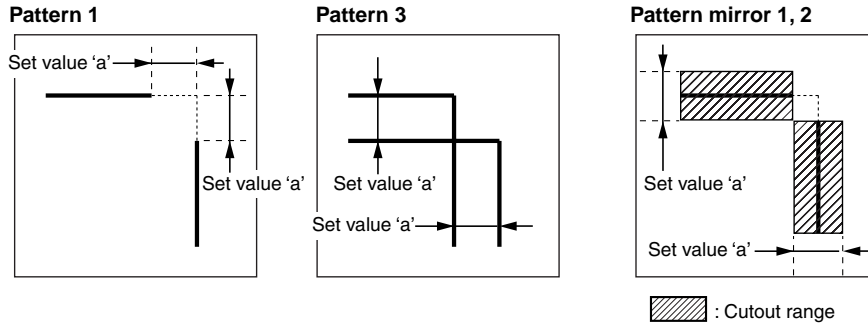

NOTE

For details on how to change the spacing between registration mark patterns, refer to Section 7.4, "Selecting the Registration MARK TYPE."

(3) The Reading Area Required for Registration Mark Detection

The figures below illustrate the reading area that this plotter requires for detecting registration marks.

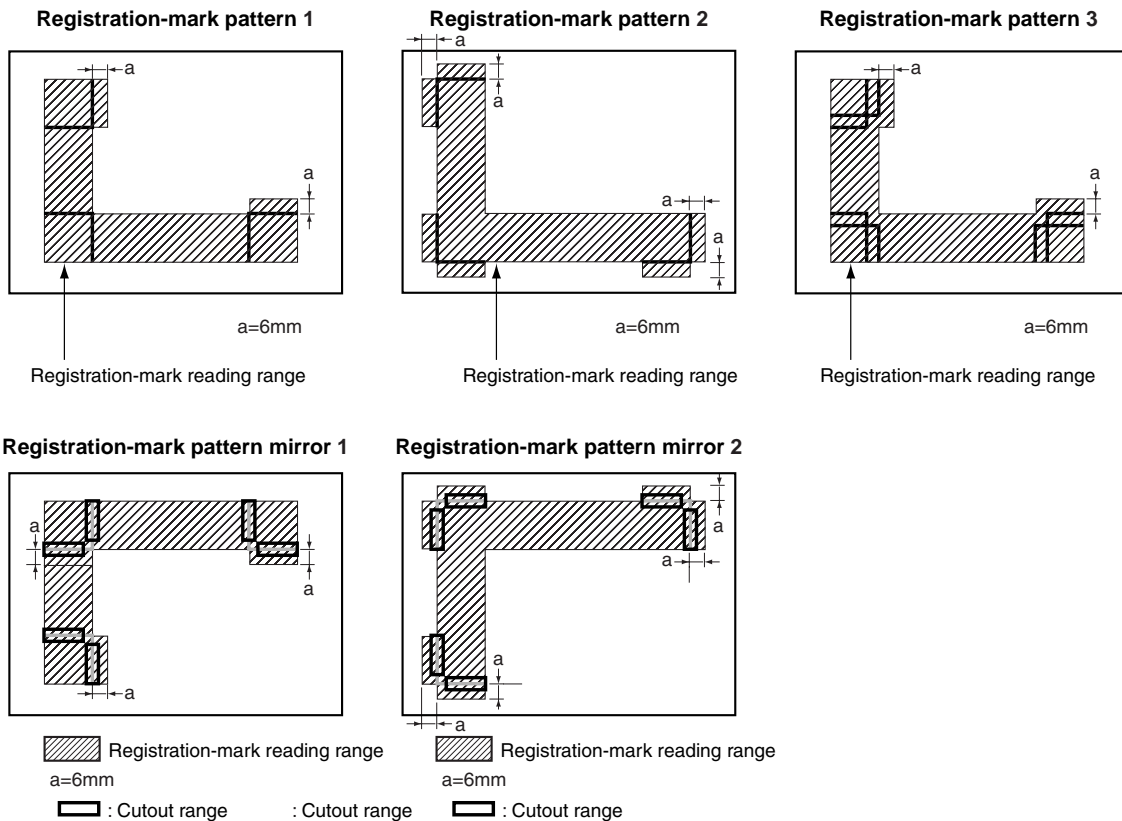

CAUTION

- Do not plot anything except registration marks within the registration mark reading area.
- If dirt, dust, or other foreign matter is adhered to the medium, the plotter may recognize it as a registration mark.
- Be sure to use only black ink for plotting registration marks.

(4) The Position of the Origin Point

After registration marks have been recognized, this plotter's origin point for plotting will be positioned as shown in the figures below.

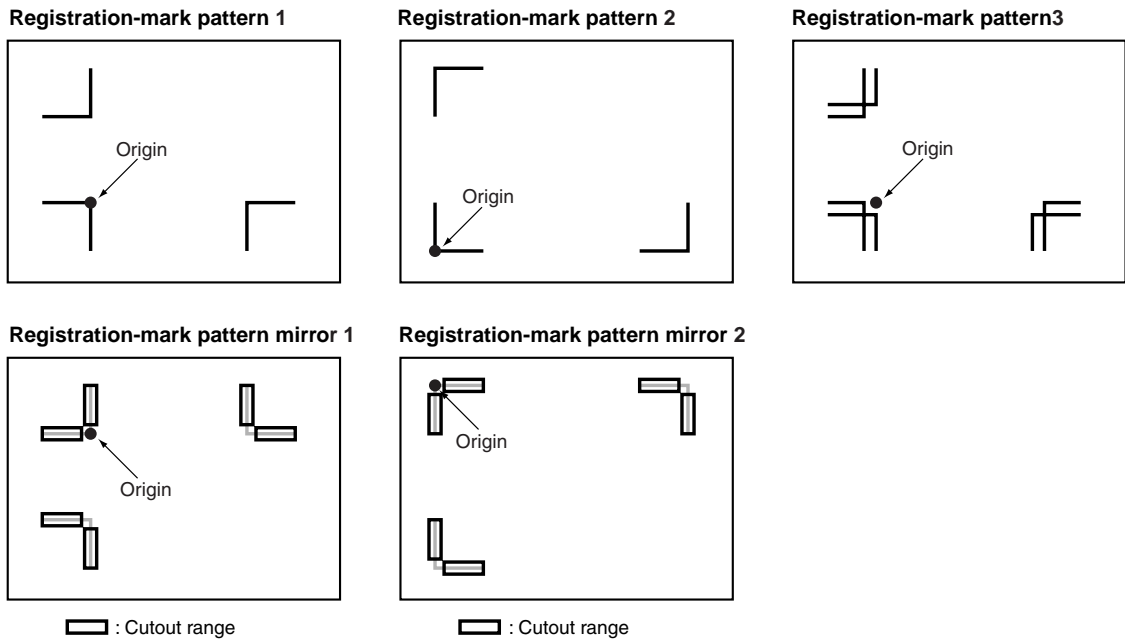

CAUTION

The origin point of plotting that is output by the software application must be adjusted to match the origin of the registration marks.

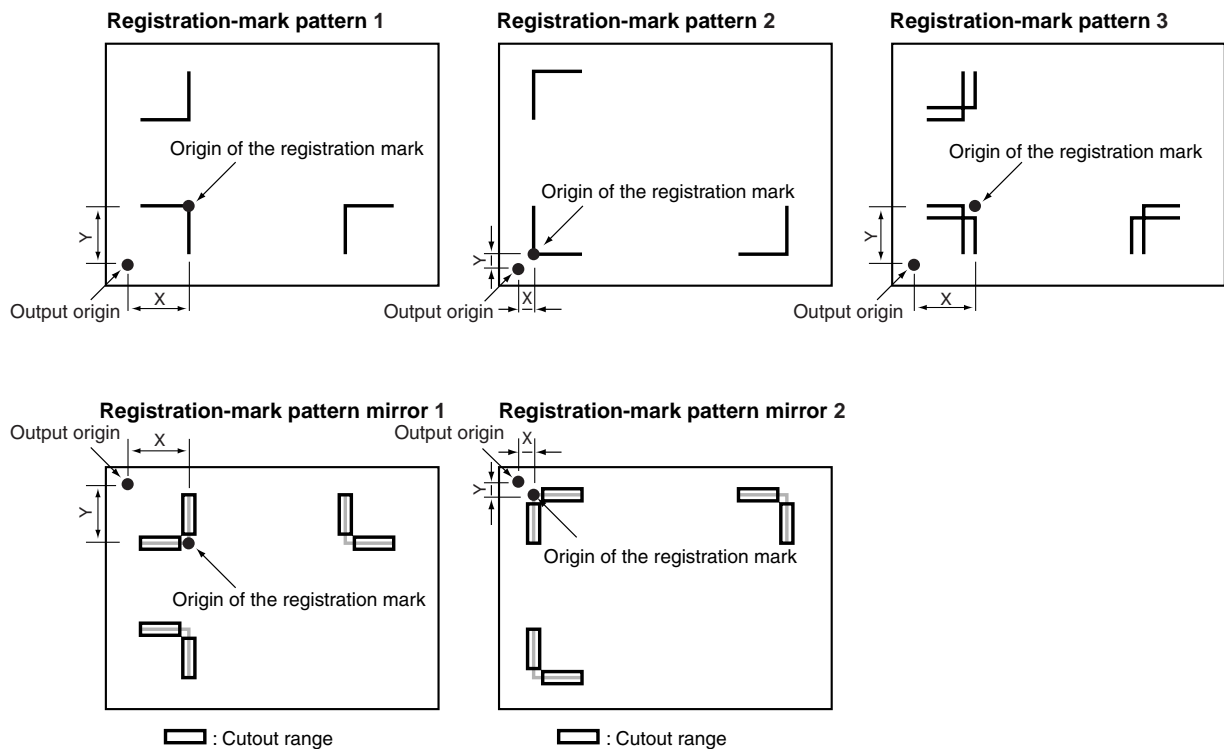

To align the output origin with the registration mark origin, measure the offset between the output origin and the registration mark origin, then input the measured distance when setting the OFFSET function (for details, see Subsection 7.6.4, "Specifying the Registration Mark OFFSET").

NOTE 

You can measure the registration mark offset using one of the two methods below.

- Read the numeric values (representing the distance from the output origin to the registration mark origin) on the screen display of your software application; or
- Plot your registration mark data and actually measure the distance between the two origin points.

(5) Media for Which Registration Marks Cannot be Detected

This plotter cannot detect registration marks for the following types of media.

- Transparent media
→ The sensor also detects the surface of the plotter's writing panel, preventing accurate recognition of registration marks.
- Plotting that does not consist of black ink on white paper
→ Use of a colored medium or registration marks of a color other than black prevents the recognition of registration marks.
- Coarsely textured drawings or media
→ A medium with a stained or wrinkled surface or faintly plotted registration marks prevents the recognition of registration marks.
- Improperly secured media
→ If the medium comes loose, the registration marks cannot be recognized.
- Excessively thick media
→ Registration marks cannot be recognized if the medium's thickness is greater than 0.3 mm.

(6) If Registration Marks Cannot be Automatically Recognized

Registration marks can also be recognized by a manual operation. For details, see Section 7.2, "Specifying the Registration MARK MODE."

When performing two-point or three-point reading, the registration-mark positions are subject to limitations. Unless the registration marks are at least 10 mm (0.4") from the plotting range in either the X or Y direction, a "Registration-mark detection error!" results. Make sure the registration marks are at least 10 mm (0.4") from the plotting range.

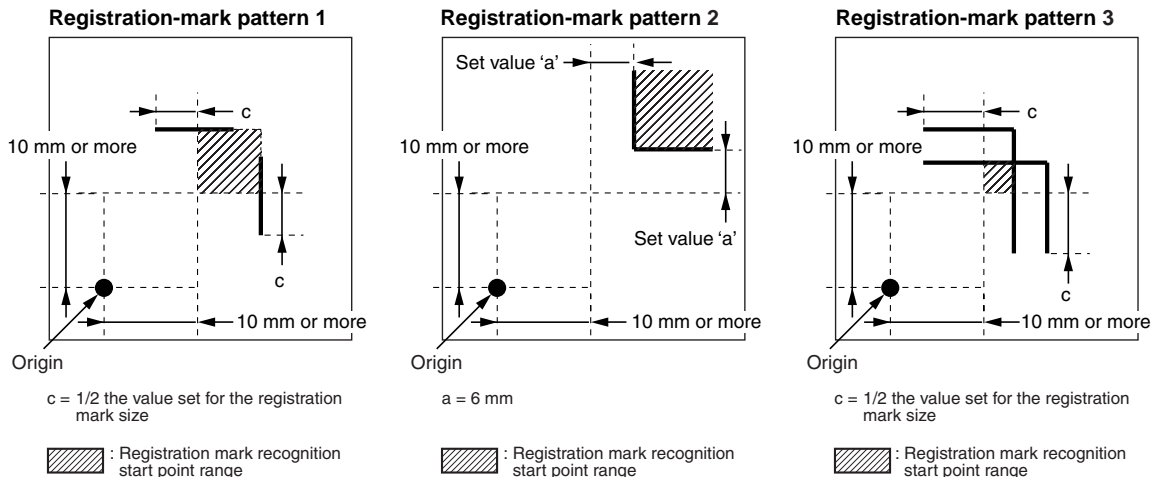

Note: Registration marks may not be recognized if the medium is located at an angle.

(7) About the Registration Mark Mirror Patterns

If Mirror 1 or Mirror 2 is selected for the registration-mark pattern, the MIRROR mode is automatically activated (see Section 6.5, "Enabling MIRROR Mode to Produce a Mirror Image").

7.2 Specifying the Registration MARK Mode

The MARK MODE function allows you to align the orientation of the plotter's X and Y axes with the coordinate axes on a medium that is pre-printed with, for example, registration marks.

NOTE

- For automatic recognition of registration marks, their line width must range from 0.2 to 1.0 mm.
- When using a combination other than black registration marks on a white medium, the plotter may not be able to recognize the registration marks.
- The registration marks may not be accurately recognized if:
 - The registration marks' lines have blurred edges;
 - There is dust or other foreign matter in the reading area; or
 - The medium comes loose from the writing panel.
- When using a medium that is not suitable for automatic registration mark recognition, use manual registration mark recognition.

Setting Procedure

- (1) Press the  PAUSE key, then press the  NEXT PAGE key until the menu below appears.

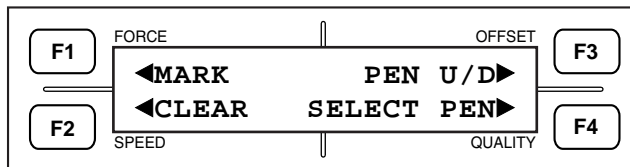



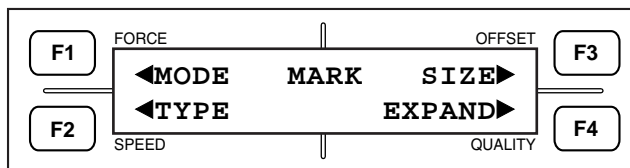

- (2) Press the  (MARK) key to display the menu below.

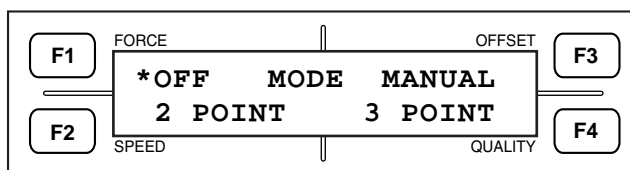

- (3) Press the  (MODE) key to display the menu below.



- (4) The currently selected setting is indicated by the asterisk (*) symbol.
 To disable registration mark recognition, press the  (OFF) key.
 To select manual registration mark recognition, press the  (MANUAL) key.
 To select two-point recognition, press the  (2 POINT) key.
 To select three-point recognition, press the  (3 POINT) key.
- (5) When the displayed setting is satisfactory, press the  ENTER key to register your setting.
 When two-point or three-point reading is selected, set the movement distance for registration-mark detection as specified in (6). If Off or Manual is selected, go to (9).
 If you selected 2 POINT or 3 POINT in Step (4), proceed to Step (6) to specify the MARK MOVE parameter.
 If you selected OFF or MANUAL in Step (4), skip to Step (9).

(6) If two-point or three-point reading is selected, the display shown below appears.

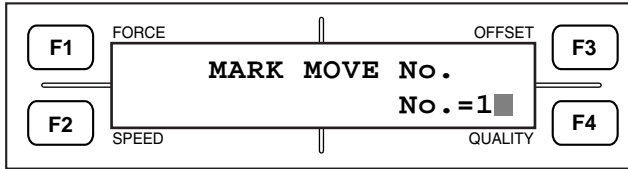



By registering the spacings at which the registration marks are to be located in advance, it is possible to move between registration marks without performing detection operation.

NOTE 

- Setting the movement distance for registration-mark detection helps to reduce the time required for it. In addition, this offers the advantage of registration-mark detection being unaffected by the presence of plotting or dirt between registration marks.
- Up to three types of registration-mark spacings can be registered.

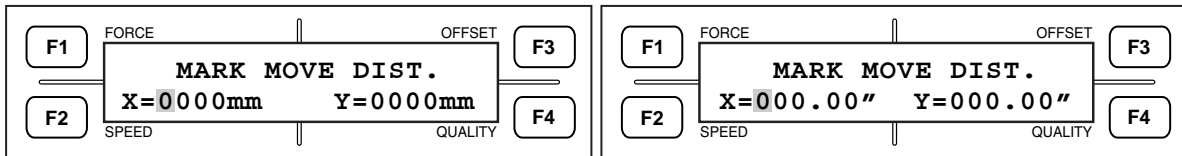
(7) Press the \triangle and ∇ POSITION key to select a register number, and then press the  ENTER key. The display shown below appears.



Enter a numeric value representing the spacing of registration marks.
 To move the  blinking cursor, press the \triangleleft or \triangleright POSITION keys.
 To change the numeric value, use the \triangle and ∇ POSITION keys.

NOTE 

- If the spacing is set to 0 mm, the spacing between registration marks is not skipped, and detection is performed continuously until the next registration mark is found.
- For two-point reading, the Y value is ignored.

(8) If the changed values are satisfactory, press the  ENTER key.

NOTE 

- If the movement distance for registration-mark detection is set correctly, the reading range required for registration-mark detection becomes as shown below.

Registration-mark pattern 1

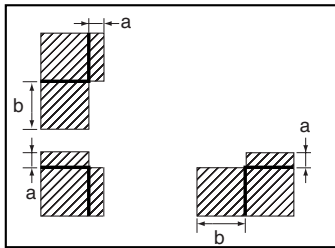

 Registration-mark recognition range
a = 6mm
b = Value set for the registration-mark size

Registration-mark pattern 2

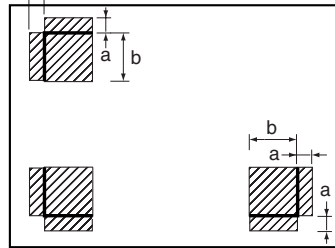

 Registration-mark recognition range
a = 6mm
b = Value set for the registration-mark size

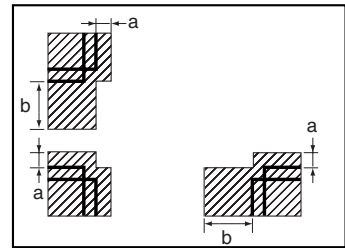

Registration-mark pattern 3



 Registration-mark recognition range
a = 6mm
b = Value set for the registration-mark size

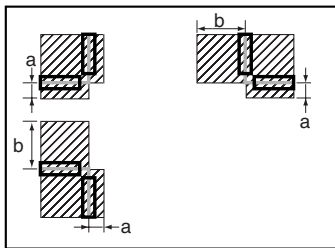

Registration-mark pattern mirror 1

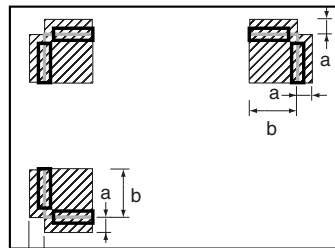

 Registration-mark recognition range
a = 6mm
b = Value set for the registration-mark size
 : Cutout range

Registration-mark pattern mirror 2



 Registration-mark recognition range
a = 6mm
b = Value set for the registration-mark size
 : Cutout range

(9) Press the  PAUSE key to return the plotter to READY status. If registration-mark recognition is set, the LCD panel display looks like the one shown below, with READY accompanied by +.

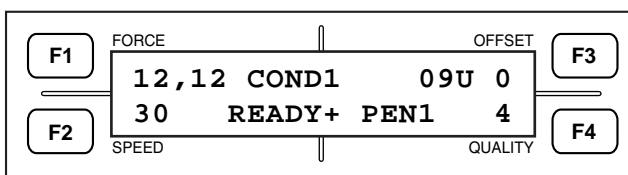

When the above display is on, press the  ORIGIN key to start correction.

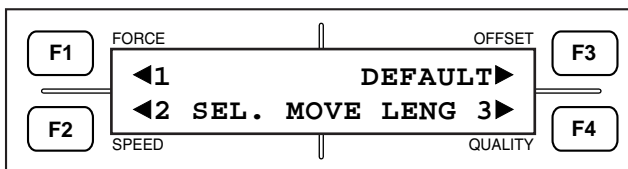

The above display appears and, when the function key for which the movement distance has been set is selected, operation begins. (Regarding the selection of the length of movement, refer to the description of how to set the movement distance for registration marks earlier in this section.)

7.3 Detection of Registration Marks

The detection of registration marks is performed using the parameters set in Section 7.2, "Specifying the Registration-Mark Mode," as described above.

- **Manual Reading** Page 7-8
- **Two-Point Reading** Page 7-10
- **Three-Point Reading** Page 7-11
- **If Mirror-Mark Cutting is Enabled** Page 7-13

If registration-mark recognition is set, a plus (+) sign appears after "READY" as in the following example.

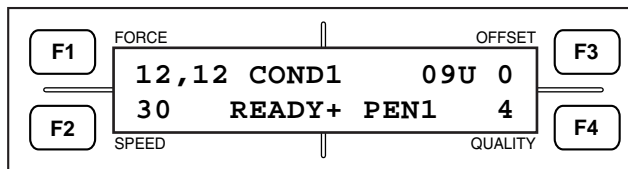

When the above menu is displayed, press the  ORIGIN key to begin correction.

7.3.1 Specifying Manual Registration Mark Recognition

The following procedure is used to manually specify registration mark recognition.

Registration-mark pattern 1, 2, 3

Registration-mark pattern mirror 1 or 2

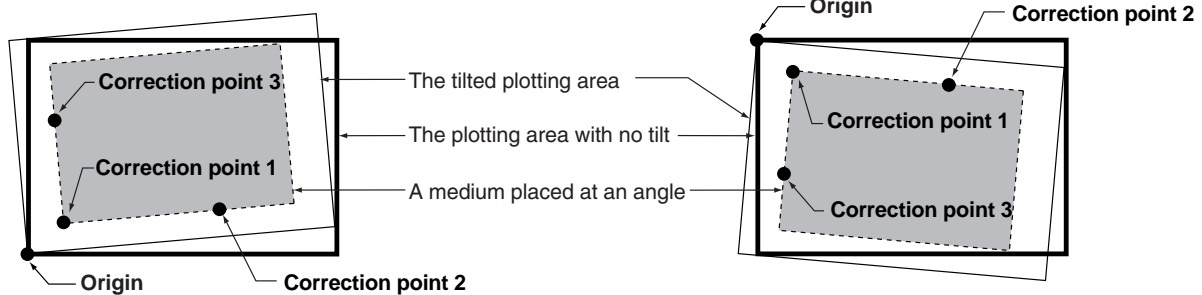





NOTE

- When the MARK DIST. ADJ. setting is OFF, 1 mm (1/16") (any value of 1 mm (1/16") or less is rounded off) or 5 mm (1/4") (any value of 5 mm (1/4") or less is rounded off), the menus for inputting corrective values shown in Step (4) do not appear after the three points have been read.
- The FIRST POINT setting becomes the origin.





Setting Procedure

- (1) Press the  ORIGIN key to display the prompt below.





F1	FORCE		OFFSET	F3
SET FIRST POINT !				
F2	SPEED		QUALITY	F4

- (2) Use the , , ,  POSITION keys to move the pen carriage to the desired FIRST POINT position, then press the  ENTER key. The prompt below appears.

F1	FORCE		OFFSET	F3
SET SECOND POINT !				
F2	SPEED		QUALITY	F4

- (3) Use the , , ,  POSITION keys to move the pen carriage to the desired SECOND POINT position, then press the  ENTER key. The prompt below appears.



F1	FORCE		OFFSET	F3
SET THIRD POINT !				
F2	SPEED		QUALITY	F4



- (4) Use the , , ,  POSITION keys to move the pen carriage to the desired THIRD POINT position, then press the  ENTER key. The menu below appears (only when the MARK DIST. ADJ. setting is OFF).

F1	FORCE		OFFSET	F3
F2	O-X	M	260.0 mm	F4
		S	0260.0 mm	
	SPEED		QUALITY	

F1	FORCE		OFFSET	F3
F2	O-X	M	000.0000"	F4
		S	000.0000"	
	SPEED		QUALITY	

The display's first line shows the distance between the 1st and 2nd points as read by the plotter, so input the actual distance in the second line.

To move the  blinking cursor, use the  and  POSITION keys.



To change the numeric value, use the  and  POSITION keys.



To register your setting, press the  ENTER key. The menu below appears (only when the MARK DIST. ADJ. setting is OFF).

F1	FORCE		OFFSET	F3
F2	O-Y	M	200.0 mm	F4
		S	0260.0 mm	
	SPEED		QUALITY	

F1	FORCE		OFFSET	F3
F2	O-Y	M	000.0000"	F4
		S	000.0000"	
	SPEED		QUALITY	

The display's first line shows the distance between the 1st and 2nd points as read by the plotter, so input the actual distance in the second line.

To move the  blinking cursor, use the  and  POSITION keys.

To change the numeric value, use the  and  POSITION keys.

To register your setting, press the  ENTER key.

- (5) After the ENTER key is pressed in Step (4) while the second menu is being displayed, the plotter returns to READY status.

7.3.2 Specifying Two-Point (2 POINT) Recognition

This following procedure describes how to align the coordinate axes based on two points. In this mode, the plotter reads two registration marks in the X-axis direction and then corrects the tilt in the X axis and adjusts the distance precision.

NOTE

When the MARK DIST. ADJ. setting is OFF, 1 mm (1/16") (any value of 1 mm (1/16") or less is rounded off) or 5 mm (1/4") (any value of 5 mm (1/4") or less is rounded off), the menu for inputting a corrective value shown in Step (3) does not appear.

Setting Procedure

- (1) Press the  ORIGIN key to display the prompt below.

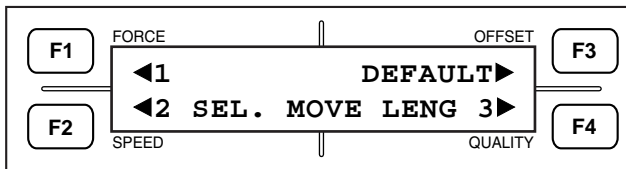

- (2) To return the pen carriage to the initial point for starting registration mark detection, press the **F3** (DEFAULT) key. To adjust the position of the registration mark origin, use the \triangleleft , \triangleleft , \triangleup , \triangledown POSITION keys to move the pen's tip within the area of the desired origin position (see the figures below).

Registration-mark pattern 1

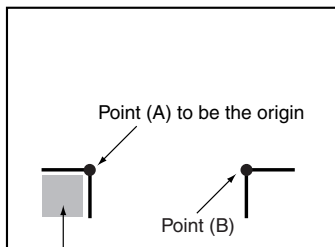

Move the tip of the pen to within this area

Registration-mark pattern 2

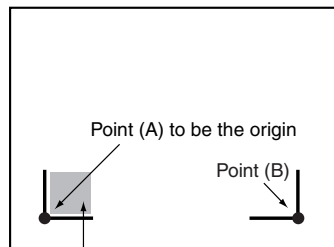

Move the tip of the pen to within this area

Registration-mark pattern 3

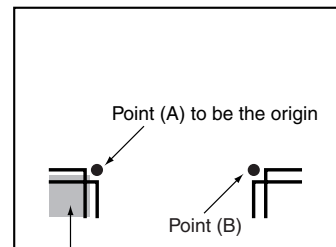

Move the tip of the pen to within this area

Registration-mark pattern mirror 1

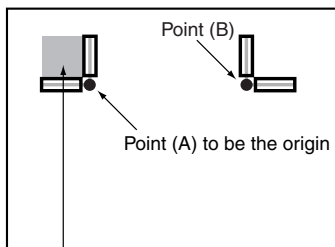

Move the tip of the pen to within this area

 : Cutout range

Registration-mark pattern mirror 2

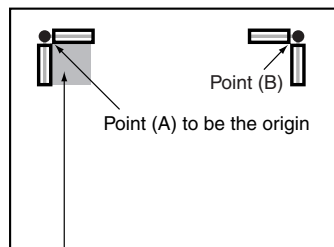

Move the tip of the pen to within this area

 : Cutout range

To begin correction, remember the number with which the spacing of registration marks was registered in “Setting the movement distance for the registration mark,” and press **F1** (No = 1), **F2** (No = 2), or **F4** (No = 3) that corresponds to that number. The display shown below will appear.

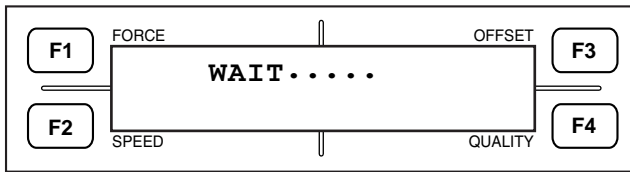

- (3) When the two points have been automatically recognized, the menu below appears (only when the MARK DIST. ADJ. setting is USER).

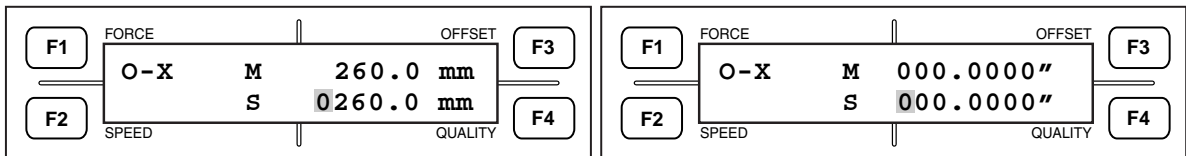

The display's first line shows the distance between the points A and B as read by the plotter, so input the actual distance in the second line.

To move the █ blinking cursor, use the \triangleleft and \triangleright POSITION keys.

To change the numeric value, use the \triangleup and \triangledown POSITION keys.

To register your setting, press the \blacktriangledown ENTER key.

- (4) After the \blacktriangledown ENTER key is pressed in Step (3), the plotter returns to READY status.

7.3.3 Specifying Three-Point (3 POINT) Recognition

This following procedure describes how to align the coordinate axes based on three points. In this mode, the plotter reads the points at the right angles of three registration marks and then corrects the tilt in both coordinate axes and adjusts the distance precision.

NOTE

When the MARK DIST. ADJ. setting is OFF, 1 mm (1/16") (any value of 1 mm (1/16") or less is rounded off) or 5 mm (1/4") (any value of 5 mm (1/4") or less is rounded off), the menu for inputting a corrective value shown in Step (3) does not appear.

Setting Procedure

- (1) Press the \oplus ORIGIN key to display the prompt below.

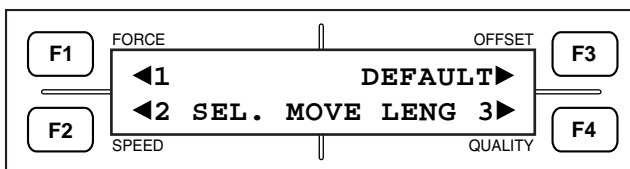

- (2) To return the pen carriage to the initial point for starting registration mark detection, press the **F3** (DEFAULT) key. To adjust the position of the registration mark origin, use the \triangleleft , \triangle , \triangleup , \triangledown POSITION keys to move the pen's tip within the area of the desired origin position (see the figures below).

Registration-mark pattern 1

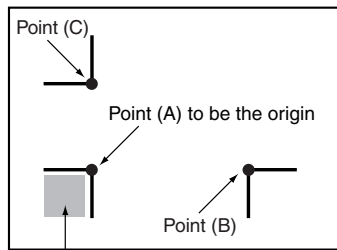

Move the tip of pen to within this area

Registration-mark pattern 2

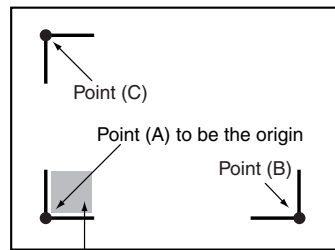

Move the tip of pen to within this area

Registration-mark pattern 3

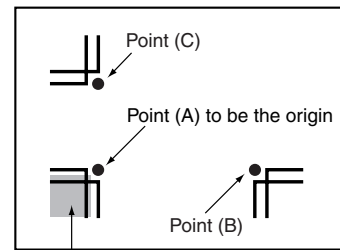

Move the tip of pen to within this area

Registration-mark pattern mirror 1

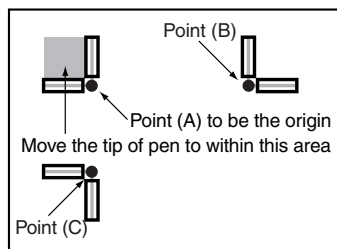

Move the tip of pen to within this area

Registration-mark pattern mirror 2

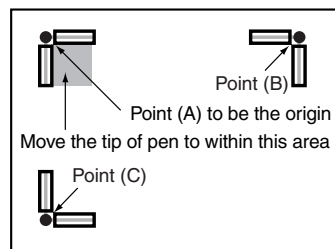

Move the tip of pen to within this area

: Cutout range

: Cutout range

To begin correction, remember the number with which the spacing of registration marks, was registered in "Setting the movement distance for the registration mark," and press **F1** (No = 1), **F2** (No = 2), or **F4** (No = 3) that corresponds to that number. The display shown below will appear.

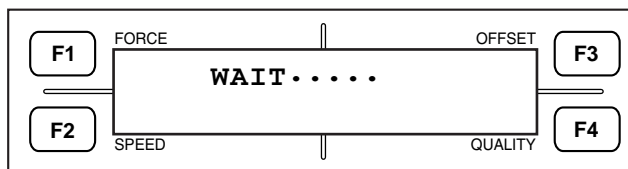

- (3) When the three points have been automatically recognized, the menu below appears (only when the MARK DIST. ADJ. setting is USER).

The display's first line shows the distance between the points A and B as read by the plotter, so input the actual distance in the second line.

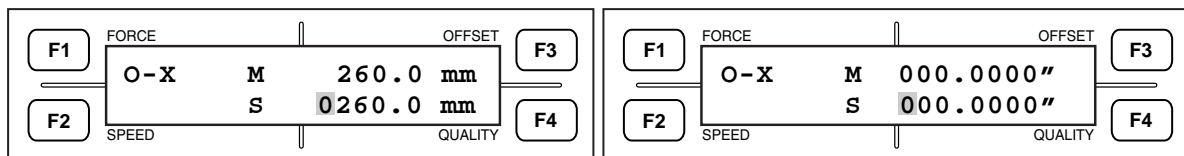

To move the blinking cursor, use the \triangleleft and \triangle POSITION keys.

To change the numeric value, use the \triangleup and \triangledown POSITION keys.

To register your setting, press the ENTER key. The menu below appears (only when the MARK DIST. ADJ. setting is OFF).

The display's first line shows the distance between the points A and C as read by the plotter, so input the actual distance in the second line.

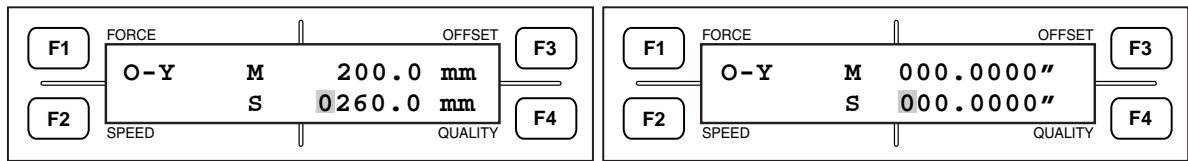

To move the █ blinking cursor, use the \triangleleft and \triangleright POSITION keys.

To change the numeric value, use the \triangleup and \triangledown POSITION keys.

To register your setting, press the \downarrow ENTER key.

- (4) After the ENTER key is pressed in Step (3) while the second menu is being displayed, the plotter returns to READY status.

7.3.4 If Mirror-Mark Cutting is Enabled

If mirror-mark cutting is enabled (7.7, "Setting Registration-Mark Detection Options"), make sure that a cutter plunger is mounted and the appropriate blade specified.

Setting Procedure

- (1) If a cutter blade has not been selected and Mirror-Mark Cutting is enabled when the \oplus ORIGIN key is pressed, the menu below appears.

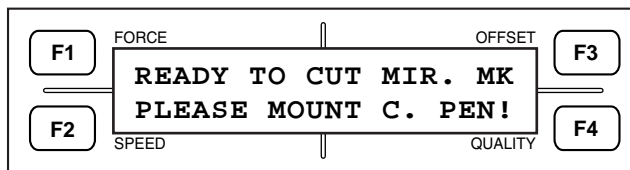

If the above menu appears, specify the type of cutter blade in the condition settings (4.3, "Specifying the Cutting Conditions"). If a cutter blade has been specified, registration-mark detection starts.

- (2) Upon completion of registration-mark detection, the menu below appears.

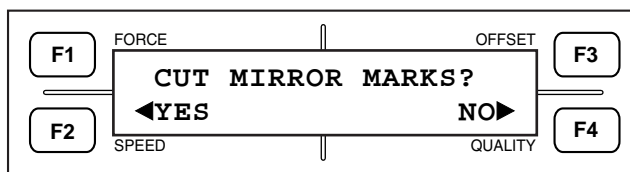

To cut out the registration marks for use in mirror recognition, press the $\boxed{F2}$ key (Yes). If you do not want to cut out the registration marks, press the $\boxed{F4}$ key (No).

- (3) Upon completion of cutting, the plotter returns to the READY status.

7.4 Selecting the Registration MARK TYPE

The MARK TYPE function is used to select the registration mark pattern of a medium that has been pre-printed with registration marks or other markings.

Setting Procedure

- (1) Press the  PAUSE key, then press the  NEXT PAGE key until the menu below appears.

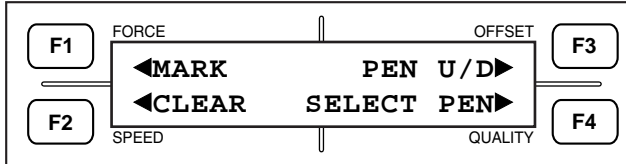

- (2) Press the **F1** (MARK) key to display the menu below.

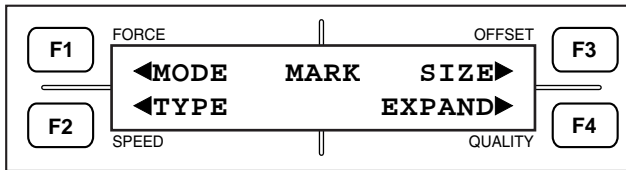

- (3) Press the **F2** (TYPE) key to display the menu below.

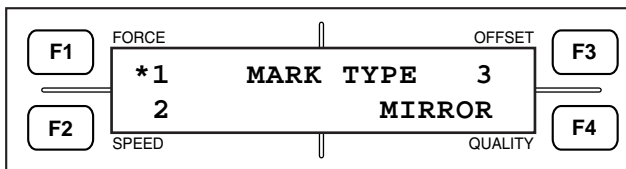

- (4) The currently selected setting is indicated by the asterisk (*) symbol.

To read registration-mark pattern 1, press the **F1** key (1).

To read registration-mark pattern 2, press the **F2** key (2).

To read registration-mark pattern 3, press the **F3** key (3).

To read registration-mark pattern mirror 1 or mirror 2, press the **F4** key (MIRROR) and select Mirror 1 or Mirror 2.

Registration-mark pattern 1

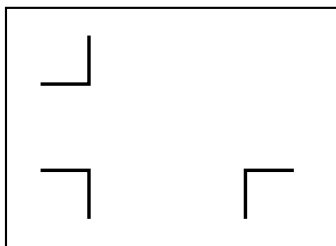

Registration-mark pattern 2

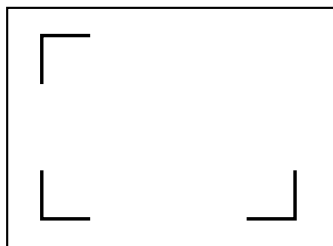

Registration-mark pattern 3

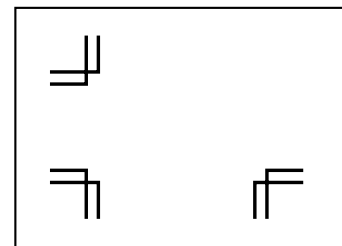

Registration-mark pattern mirror 1

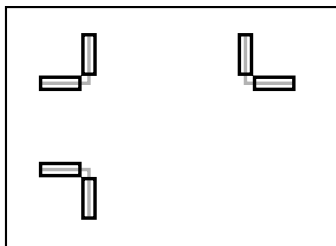

Registration-mark pattern mirror 2

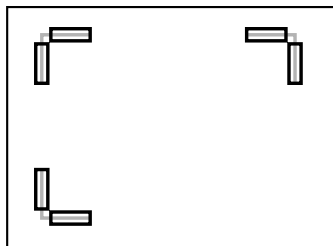

 : Cutout range

 : Cutout range

For Registration-mark pattern 1

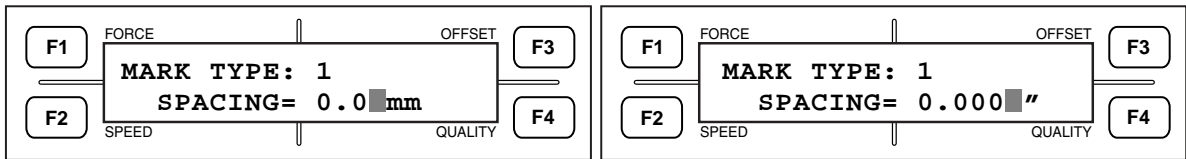

If “1 (Registration-mark pattern 1)” is set and the  ENTER key in (4) above is pressed, the menu below appears.

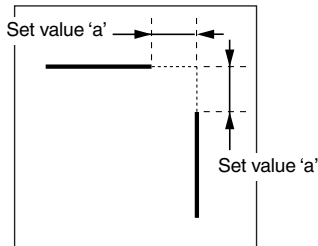

Set the spacing of registration marks.

Registration-mark pattern 1



Shown at the  blinking cursor is the currently set value. Pressing the  or  POSITION keys enables the spacing of registration-mark pattern 1 to be changed. The value can be set in the range of 0 to 9.9 mm (0 to 0.398”).

Go to (5) if the setting of the registration-mark distance correction is off (see 7.6, “Specifying Other Registration-Mark Parameters”), or go to (6) if it is on.

For Registration-mark pattern 3

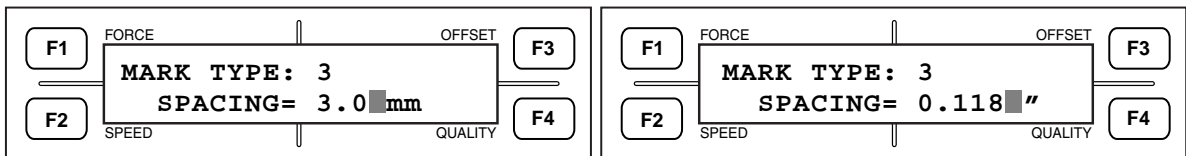

If “3 (Registration-mark pattern 3)” was set and the  ENTER key in (4) above is pressed, the menu below appears.

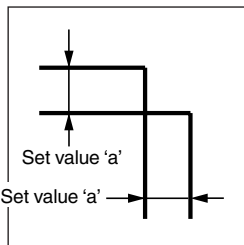

Set the spacing of registration marks.

Registration-mark pattern 3



Shown at the  blinking cursor is the currently set value. Pressing the  or  POSITION keys allows the spacing of registration-mark pattern 3 to be changed. The value can be set in the range of 0 to 9.9 mm (0 to 0.398”).

Go to (5) if the setting of the registration-mark distance correction is off (see 7.6, “Specifying Other Registration-Mark Parameters”), or go to (6) if it is on.

For Registration-mark pattern mirror 1 or 2

If "MIRROR (**F4** key)" in (4) above is pressed, the menu below appears.

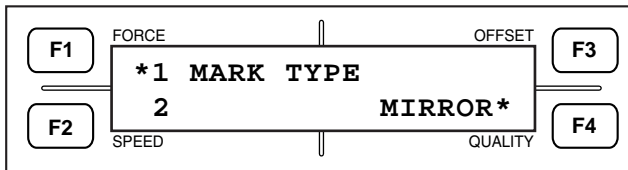

To read registration-mark pattern mirror 1, press the **F1** key (1).

To read registration-mark pattern mirror 2, press the **F2** key (2).

To return to the display of registration-mark patterns 1, 2, or 3, press the **F4** key (MIRROR).

When the above display is shown, set "1 (registration-mark pattern mirror 1)" or "2 (registration-mark pattern mirror 2)" (when mirror cutting is enabled), then press the **ENTER** key. The menu below appears.

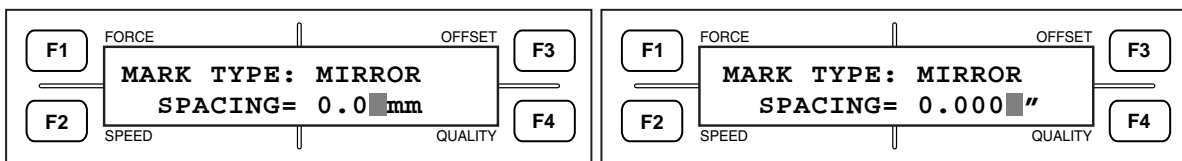

Set the spacing of registration marks.

Registration-mark pattern mirror 1 Registration-mark pattern mirror 2

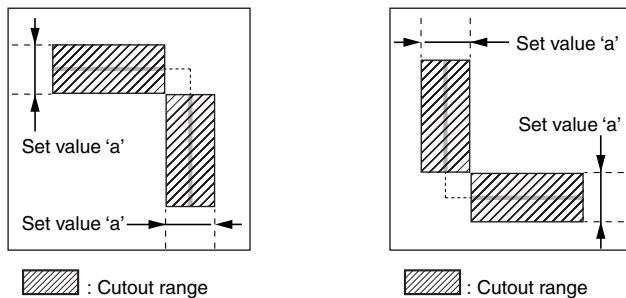

For this spacing, set the same value that you set for the registration-mark spacing when performing mirror cutting. The set value is stored in memory with the same value set as when the mirror cutting was enabled.

The **█** blinking cursor illustrates the currently set value. Pressing the **△** or **▽** POSITION keys allows the spacing of registration-mark pattern mirror 1 to be changed. The value can be set in a range from 0 to 9.9 (mm).

Go to (6) if the registration-mark pattern is Mirror 1 or Mirror 2.

- (5) If the setting of registration-mark distance correction is off and the **ENTER** key is pressed on the above display (see 7.5, "Specifying Other Registration-Mark Parameters"), the display shown below appears.

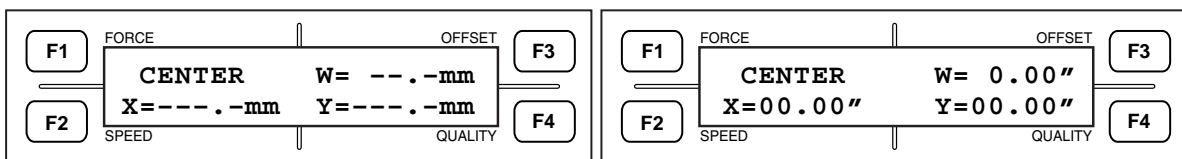

* This menu is not shown for registration-mark pattern mirrors 1 and 2.

To perform plotting with respect to the center registration mark, press the **F1** key (1). The menu below appears.

To perform plotting without using the center registration mark, press the **F1** key (1) and remove the asterisk (*), then press the **ENTER** key.

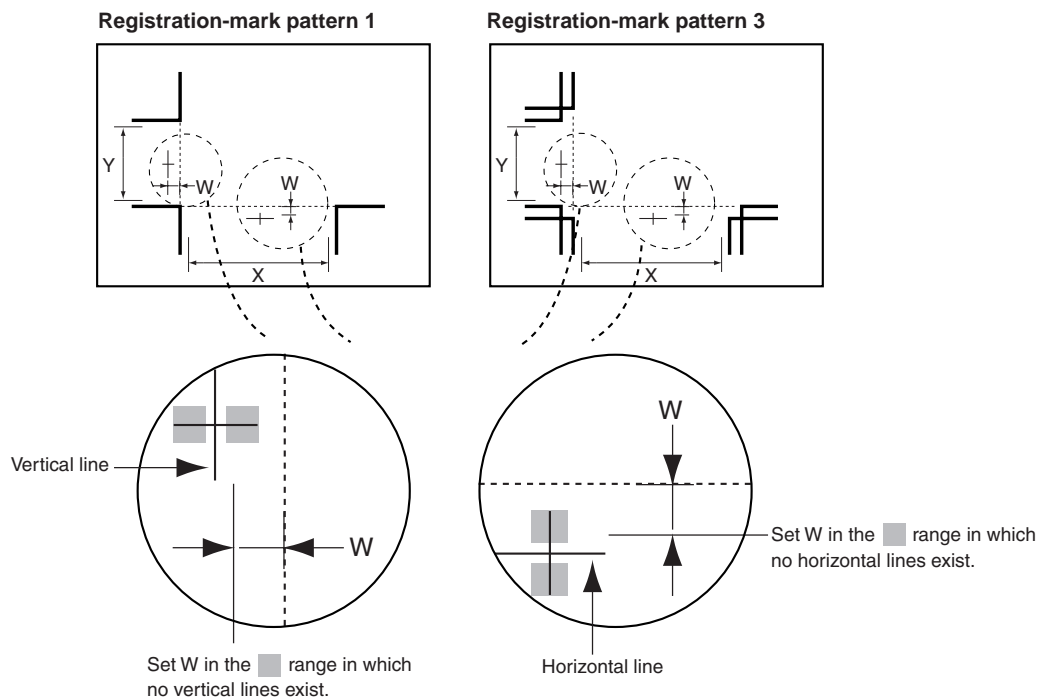

In this status, press one of the **F2** to **F4** keys to change X (X-axis length), W (center-registration-mark read position), or Y (Y-axis length).

To move the **█** blinking cursor while the set values are displayed, press the **◀** or **▶** POSITION key.

Pressing the **△** or **▽** POSITION keys allows the value to be changed.

The value can be set in the range of 0 to 999.9 for X, -99.9 to +99.9 for W, and 0 to 999.9 for Y when using mm units, and 0 to 39.36 for X, -3.93 to +3.93 for W, and 0 to 39.36 for Y when using inch units.

- (6) When the displayed setting is satisfactory, press the **ENTER** key to register your setting.
- (7) Press the **■** PAUSE key to return the plotter to READY status.

7.5 Specifying the Registration MARK SIZE

The MARK SIZE function lets you specify the size of registration marks for a medium that is pre-printed with registration marks or other markings.

Setting Procedure

- (1) Press the  PAUSE key, then press the  NEXT PAGE key until the menu below appears.

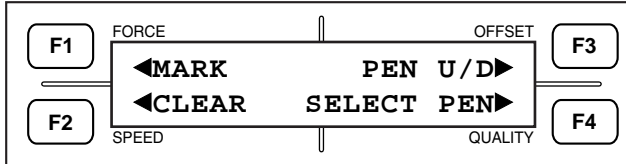

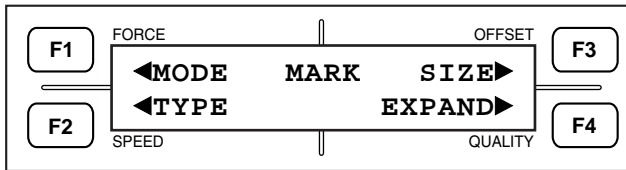

- (2) Press the **F1** (MARK) key to display the menu below.

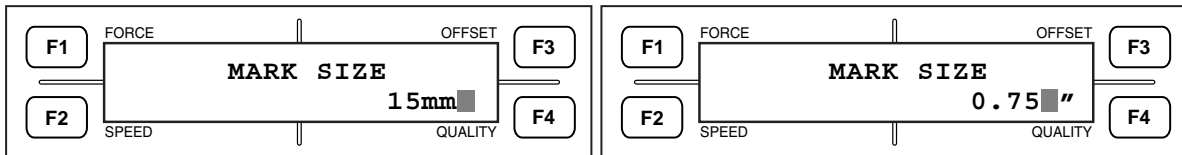

- (3) Press the **F3** (SIZE) key to display the menu below.



- (4) The currently selected setting is indicated by the  blinking cursor. Use the ,  POSITION keys to change the MARK SIZE setting in a range from 5 to 20 mm (0.20 to 0.80").

Registration-mark pattern 1

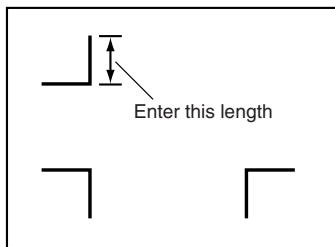

Registration-mark pattern 2

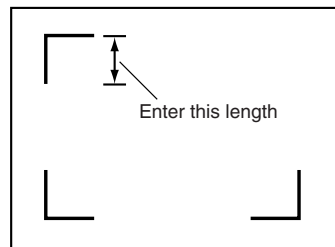

Registration-mark pattern 3

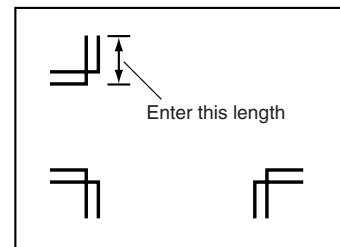

Registration-mark pattern mirror 1

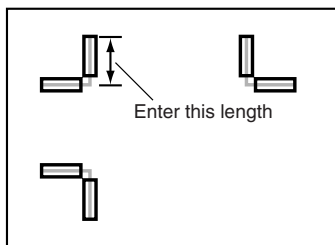

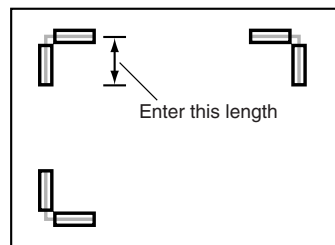

Registration-mark pattern mirror 2



 : Cutout range

 : Cutout range

- (5) When the displayed setting is satisfactory, press the  ENTER key to register your setting.

- (6) Press the  PAUSE key to return the plotter to READY status.

7.6 Specifying Other Parameters Related to Registration Marks

Selecting the EXPAND parameter gives you access to other functions for adjusting the distance precision method for registration marks (MARK DIST. ADJ.), adjusting the registration mark sensor (MARK ADJ. SENS), specifying the registration MARK OFFSET, and specifying the ADJ. SENS+ function.

- **Adjusting the Distance Precision for Registration Marks** Page 7-19
- **Adjusting the Registration Mark Sensor** Page 7-21
- **Adjusting the Sensor by Printing a Cross Pattern** Page 7-23
- **Specifying the Registration MARK OFFSET** Page 7-25
- **Registration-Mark Detection Options** 7.7 Specifying Registration-Mark Detection Options

7.6.1 Adjusting the Distance Precision for Registration Marks

The MARK DIST. ADJ. function selects the method for adjusting the distance precision for registration marks (Manual, Two-Point, Three-Point). The distance between registration marks is automatically corrected to a value that is divisible by 1 or 5 mm.

A setting (User) for manually entering the distance between registration marks and a setting (Off) for not performing distance correction are also available.

NOTE

- If the distance correction was set to 5 mm, for example, and the distance between registration marks read is 312 mm, distances below 5 mm are rounded off to the nearest whole number and the distance between registration marks is assumed to be 310 mm, as distance correction is executed.
- If the registration-mark distance correction was set to 1 mm, provide spaces between registration marks in units of 1 mm when creating registration marks in your CAD application. If it was set to 5 mm, provide spaces between registration marks in units of 5 mm when creating registration marks in your CAD application.
- For media that tends to expand or shrink, or when correcting a distance using values that cannot be divided by 1 mm without a remainder, choose “Manual.”

Example of registration-mark distance correction (when the distance between registration marks on CAD is 310 mm)

Setting of distance correction	Distance between registration marks in the CAD application	Distance between registration marks read by the plotter	Value for distance correction
1 mm	310 mm	309.5 mm ≤ readout ≤ 310.5 mm	310 mm
5 mm	310 mm	307.5 mm ≤ readout ≤ 312.5 mm	310 mm

Setting Procedure

- (1) Press the  PAUSE key, then press the  NEXT PAGE key until the menu below appears.

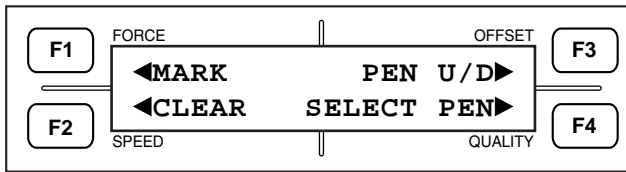

- (2) Press the **F1** (MARK) key to display the menu below.

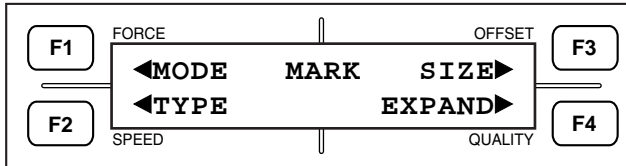

- (3) Press the **F4** (EXPAND) key to display the menu below.

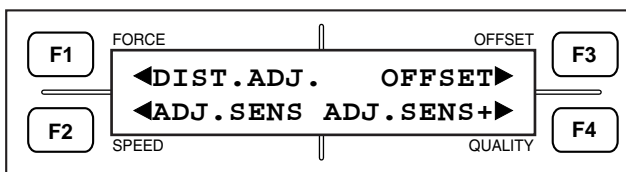

- (4) Press the **F1** (DIST. ADJ.) key to display the menu below.

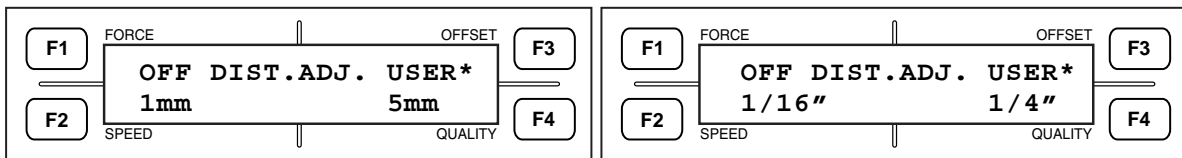

- (5) The currently selected setting is indicated by the asterisk (*) symbol.

To enable user-specified distance adjustment (manual input), press the **F3** (USER) key.

To select 1-mm (1/16") distance adjustment (any value of 1 mm (1/16") or less is rounded off), press the **F2** key.

To select 5-mm (1/4") distance adjustment (any value of 5 mm (1/4") or less is rounded off), press the **F4** key.

To disable distance adjustment, press the **F1** (OFF) key.

- (6) When the displayed setting is satisfactory, press the  ENTER key to register your setting.

- (7) Press the  PAUSE key to return the plotter to READY status.

7.6.2 Adjusting the Registration Mark Sensor

The MARK ADJ. SEN function lets you adjust the registration mark recognition sensor by plotting a cross symbol, reading it, and plotting another cross symbol for use in adjustment. The sensor's precision can be adjusted by inputting a corrective value to compensate for any error.

Setting Procedure

- (1) Press the  PAUSE key, then press the  NEXT PAGE key until the menu below appears.

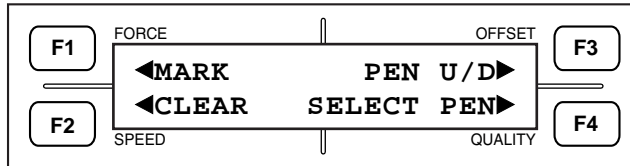

- (2) Press the  (MARK) key to display the menu below.

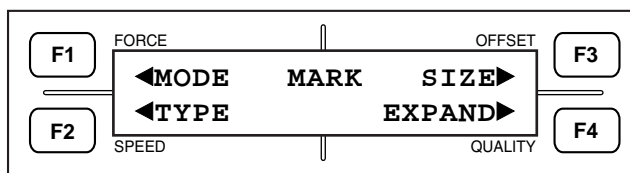

- (3) Press the  (EXPAND) key to display the menu below.

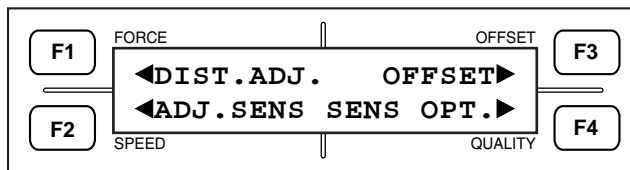

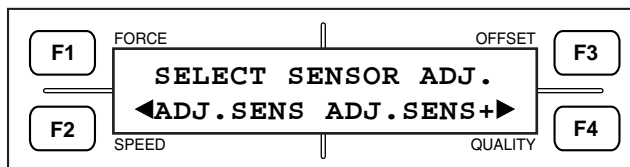

- (4) Press the  (ADJ. SENS) key to display the menu below.



- (5) Press the  (ADJ. SENS) key to display the menu below.



To correct X or Y for the sensor, use the  key (X) or  key (Y) in order to display an asterisk (*).

- (6) Use the ◀, ▶, ▲, ▼ POSITION keys to move the pen carriage to the position near the cross symbol indicated in the figure below, then press the  ENTER key.

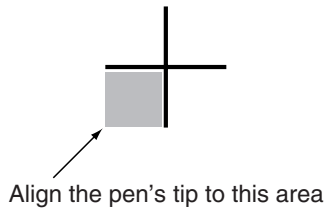



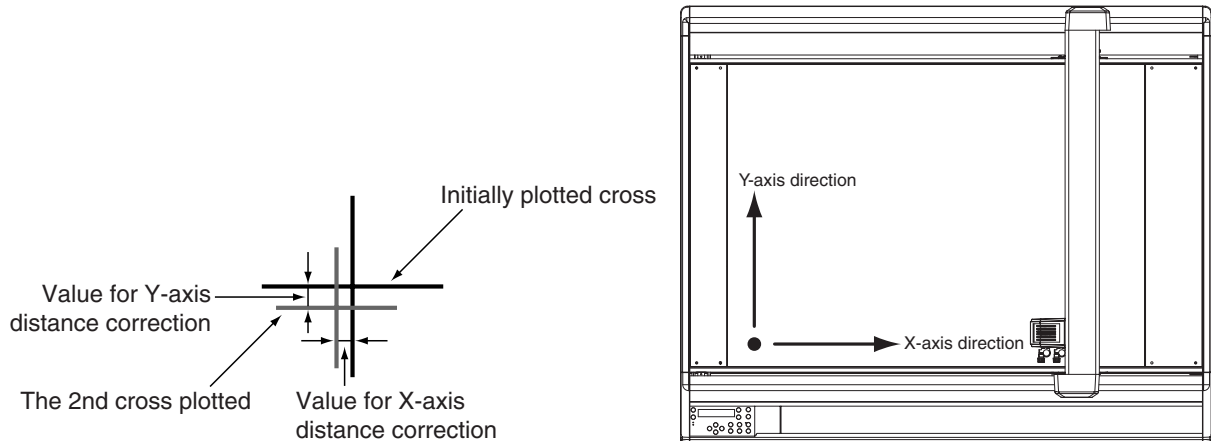

After the sensor reads the cross symbol, a cross symbol for use in adjustment is plotted using the pen in Pen Holder 1 (see the figure below).

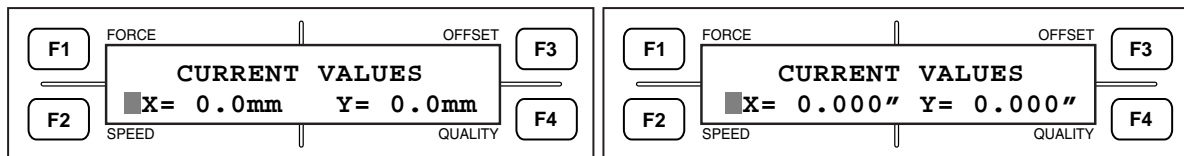

- (7) After the sensor reads the cross symbol plotted for use in adjustment, the menu below appears.



- (8) Press the  (X=) or  (Y=) key to move the  blinking cursor to the value to be corrected. To change the corrective value for sensor adjustment, use the ▲ and ▼ POSITION keys. (If no correction is required, skip to Step (9)).
- (9) When the displayed setting is satisfactory, press the  ENTER key to register your setting.
- (10) Press the  PAUSE key to return the plotter to READY status.

7.6.3 Adjusting the Sensor by Printing a Cross Pattern

The ADJ. SENS+ function plots a cross symbol, reads it, and plots another cross symbol for use in determining the corrective values you should input in order to adjust the registration mark sensor's precision.

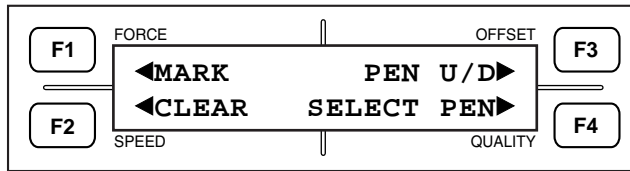

Setting Procedure

- (1) Press the  PAUSE key, then press the  NEXT PAGE key until the menu below appears.



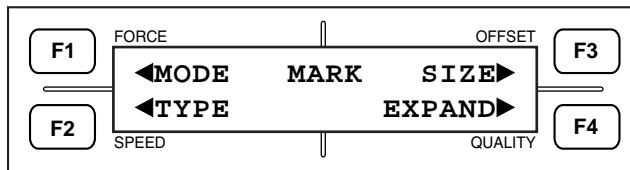

- (2) Press the  (MARK) key to display the menu below.

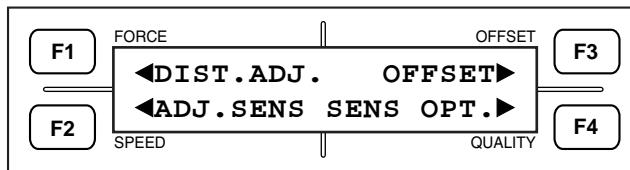

* If the setting of the registration-mark mode (7.2, "Specifying the Registration-Mark Mode") is OFF, the  to  keys are not displayed.

- (3) Press the  (EXPAND) key to display the menu below.



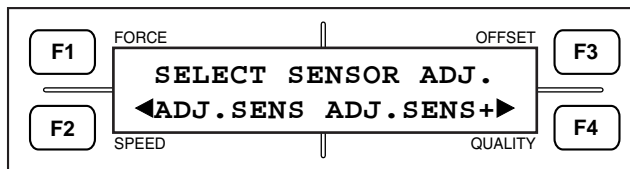

- (4) Press the  key (ADJ. SENS) to display the menu below.

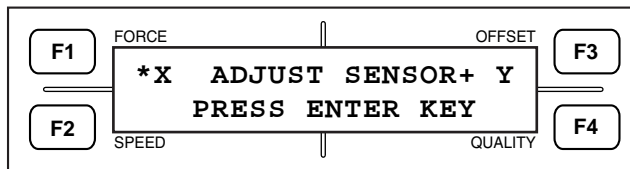

- (5) Press the  key (ADJ. SENS+) to display the menu below.





To correct X or Y for the sensor, use the  key (X) or  key (Y) in order to display an asterisk (*).

Press the  ENTER key. The plotter draws a cross and reads it using the sensor. It then draws a second cross for correction purposes.

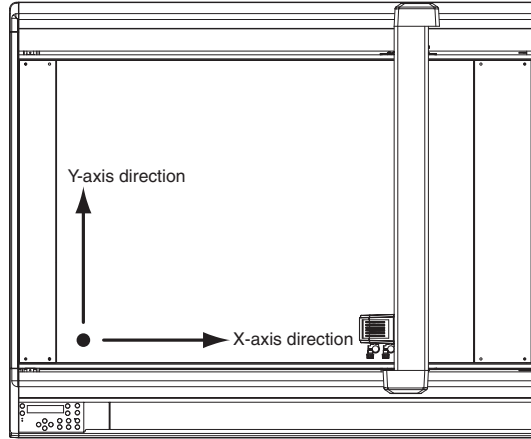
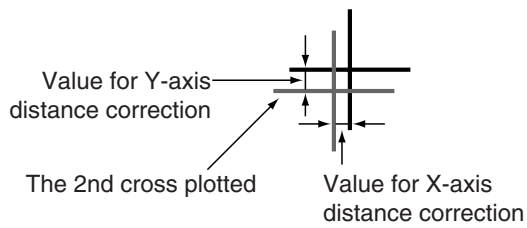
(6) After reading is performed, the menu below appears.



- (7) Press the **F2** or **F4** key. The ■ blinking cursor moves to X or Y, allowing you to change the amount of correction. Enter a value representing the distance between the first cross drawn and the cross drawn after reading. (In the case of the above diagram, for example, enter X = -*.* , Y = -*.*.) Use the \triangle and ∇ POSITION keys to change the values.
- (8) When the displayed settings are satisfactory, press the  ENTER key to register your settings.
- (9) Press the  PAUSE key to return the plotter to READY status.

7.6.4 Specifying the Registration MARK OFFSET

Unless the origin point has been moved to a new position, it is located at the lower left corner of the effective cutting/plotting area. Use the MARK OFFSET function when you wish to move the origin of the registration mark.

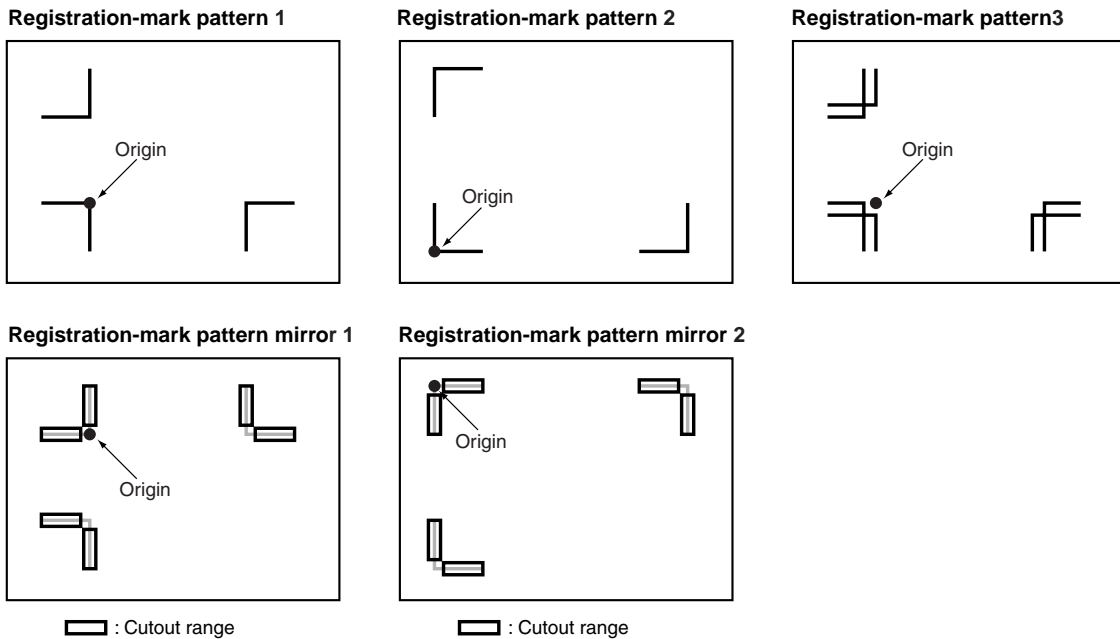

Setting Procedure

- (1) Press the PAUSE key, then press the NEXT PAGE key until the menu below appears.

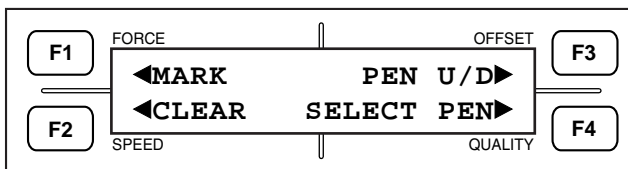

- (2) Press the **F1** (MARK) key to display the menu below.

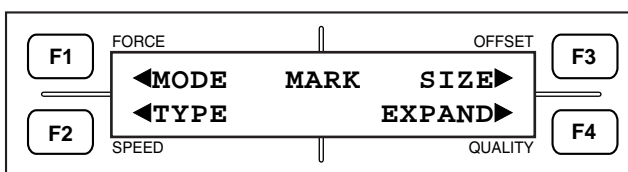

- (3) Press the **F4** (EXPAND) key to display the menu below.

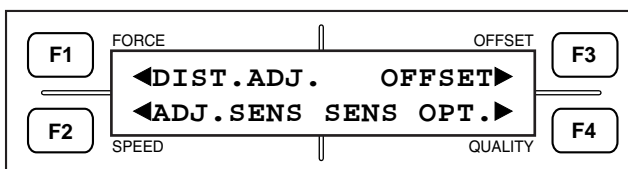

- (4) Press the **F3** (OFFSET) key to display the menu below.

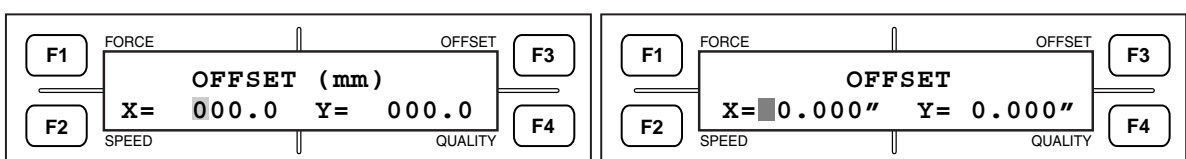

- (5) For offset values (distance from the registration mark), press the ◀ or ▶ POSITION key to move the ■ blinking cursor. Then press the ▲ or ▼ POSITION key to change the value.

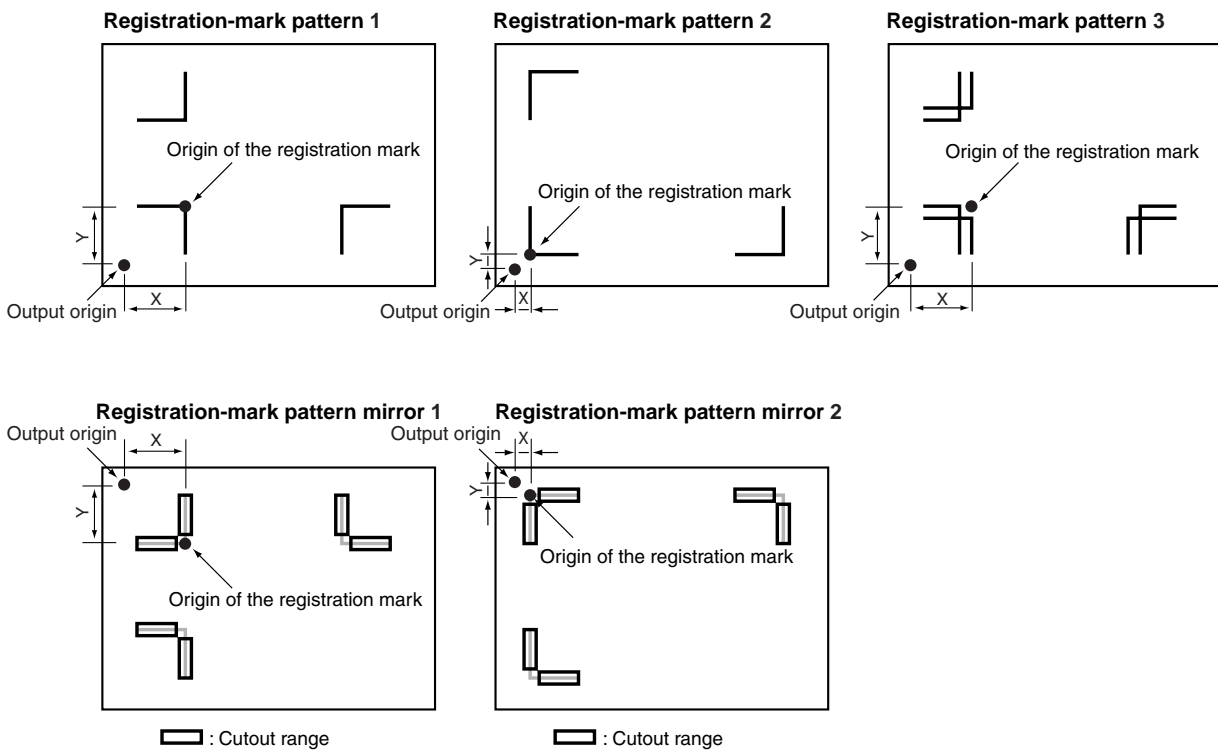

- (6) When the displayed settings are satisfactory, press the ↵ ENTER key to register your settings.

- (7) Press the ■ PAUSE key to return the plotter to READY status.

7.7 Specifying Registration-Mark Detection Options

This function is provided for setting the parameters associated with registration-mark detection, such as the speed, level, registration-mark cutting, and sensing intervals.

- **Setting the Speed of Registration-mark Detection** Page 7-27
- **Setting the Registration-mark Detection Level** Page 7-28
- **Setting the Registration-mark Cutting Function** Page 7-30
- **Setting the Sensing Intervals** Page 7-32

7.7.1 Setting the Speed of Registration-mark Detection

Set the speed at which the lines of registration marks are detected. Change speed settings if, unless the speed is changed, registration marks cannot be detected due to the type of media or the thickness of registration-mark lines.

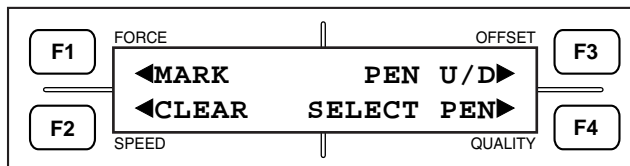

Setting Procedure

- (1) Press the  PAUSE key, followed by the  NEXT PAGE key. The menu below appears.

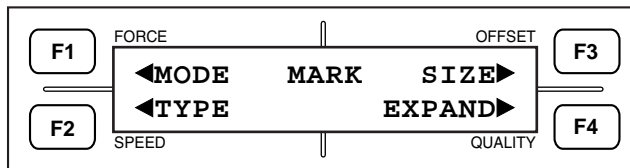

- (2) Press the  key (MARK) to display the menu below.



* If the setting of the registration-mark mode (7.2, “Specifying the Registration-Mark Mode”) is OFF, the  to  keys are not displayed.

- (3) Press the  key (EXPAND) to display the menu below.

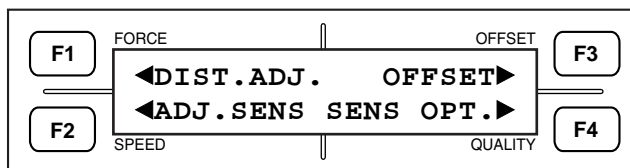

- (4) Press the  key (SENS OPT.) to display the menu below.

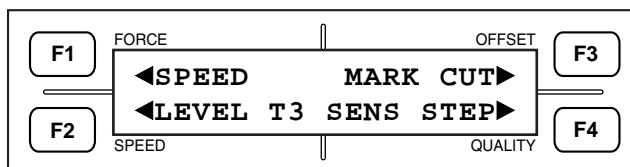

- (5) Press the **F1** key (SPEED) to display the menu below.

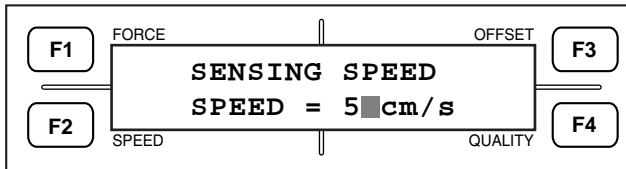

Press the \triangle or ∇ POSITION key to change the value. The value can be set in the range of 1 to 30 (cm/s). When the displayed setting is satisfactory, press the ENTER key to register your setting.

- (6) Press the **PAUSE** key to return the plotter to READY status.

7.7.2 Setting the Registration-mark Level

Set the level at which to determine the presence of line segments for each registration-mark pattern. This level is specified by the percentage change from the sensor level in parts where there are no line segments. A line segment is assumed to be present when there is a specified amount of change in the level.

Setting Procedure

- (1) Press the **PAUSE** key, followed by the **NEXT PAGE** key. The menu below appears.

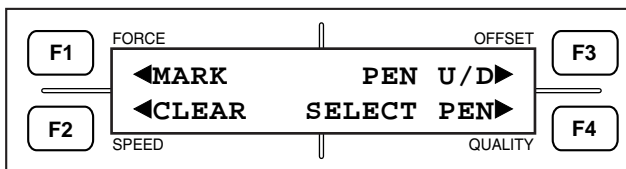

- (2) Press the **F1** key (MARK) to display the menu below.

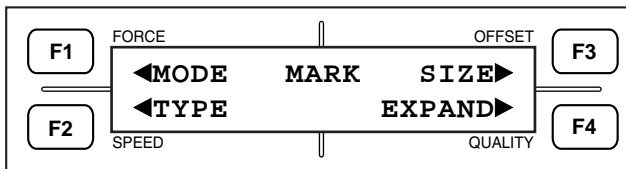

* If the setting of the registration-mark mode (7.2, "Specifying the Registration-Mark Mode") is OFF, the **F2** to **F4** keys are not displayed.

- (3) Press the **F4** key (EXPAND) to display the menu below.

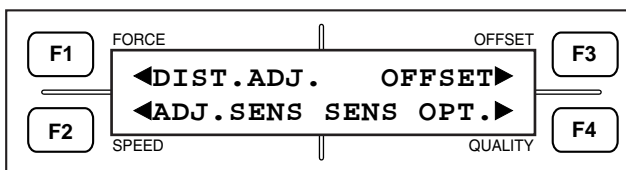

- (4) Press the **F4** key (SENS OPT.) to display the menu below.

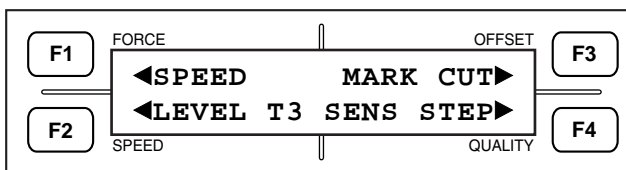

(5) Press the **F2** key (LEVEL) to display the menu below.



To set the level for registration-mark patterns 1 and 2, press the **F2** key (1, 2).

To set the level for registration-mark pattern 3, press the **F3** key (3).

To set the level for registration-mark mirrors 1 and 2, press the **F4** key (MIRROR).



CAUTION

The lower the level-setting value, the higher the sensitivity. However, the floating up of paper from the surface or dirt on the paper may cause erroneous detection.

For registration-mark patterns 1 and 2

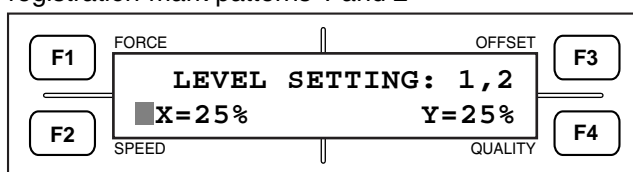

Press the **F2** key or **F4** key; the █ blinking cursor moves to X or Y, allowing the amount of correction to be changed.

Use the \triangle and ∇ POSITION keys to change the value.

When the displayed settings are satisfactory, press the  ENTER key.

For registration-mark pattern 3

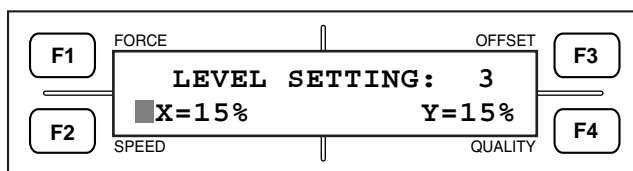

Press the **F2** key or **F4** key; the █ blinking cursor moves to X or Y, allowing the amount of correction to be changed.

Use the \triangle and ∇ POSITION keys to change the value.

When the displayed settings are satisfactory, press the  ENTER key.

For registration-mark pattern mirrors 1 and 2



Press the **F2** key or **F4** key; the █ blinking cursor moves to X or Y, allowing the amount of correction to be changed.

Use the \triangle and ∇ POSITION keys to change the value.

When the displayed settings are satisfactory, press the  ENTER key.

(6) Press the  PAUSE key to return the plotter to READY status.

7.7.3 Setting the Registration-mark Cutting Function

After detecting registration marks, specify whether to cut the registration marks for mirror use. The registration-mark pattern that can be cut for this purpose is registration-mark pattern 1 or 2.

CAUTION

When cutting registration marks, make sure an adhesive mat is pasted to the plotter's writing panel. If registration marks are cut while an adhesive sheet is pasted to the writing panel, registration marks in the cutouts cannot be detected.

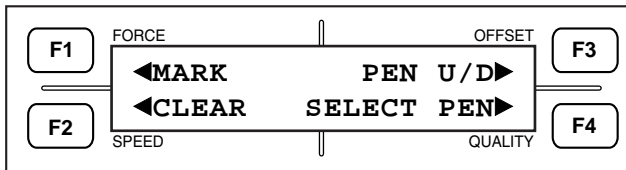

Setting Procedure

- (1) Press the  PAUSE key, followed by the  NEXT PAGE key. The menu below appears.



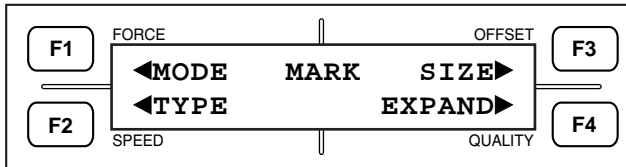

- (2) Press the  key (MARK) to display the menu below.

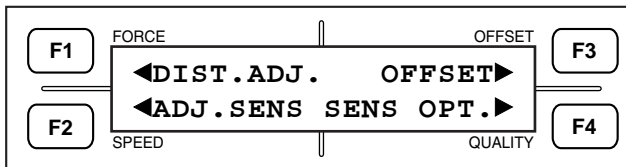

* If the setting of the registration-mark mode (7.2, "Specifying the Registration-Mark Mode") is OFF, the  to  keys are not displayed.

- (3) Press the  (EXPAND) key to display the menu below.



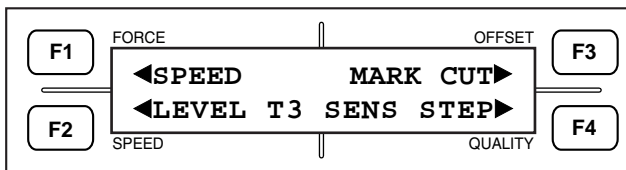

- (4) Press the  (SENS OPT.) key to display the menu below.

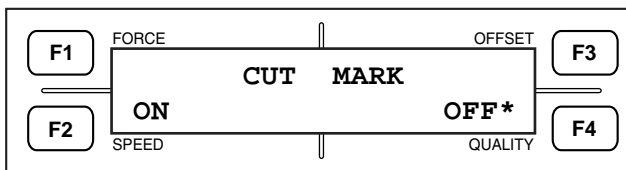

- (5) Press the  key (MARK CUT) to display the menu below.



- (6) The currently set value is marked with an asterisk (*). To cut a registration mark, press the  key (ON). If a registration mark is not to be cut, press the  key (OFF).

- (7) When the displayed setting is satisfactory, press the  ENTER key.

When CUT MARK is turned on, the display becomes as shown below.

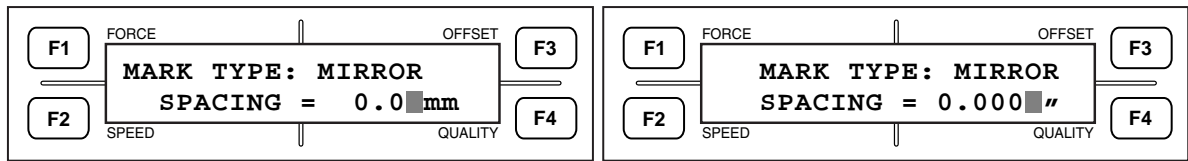

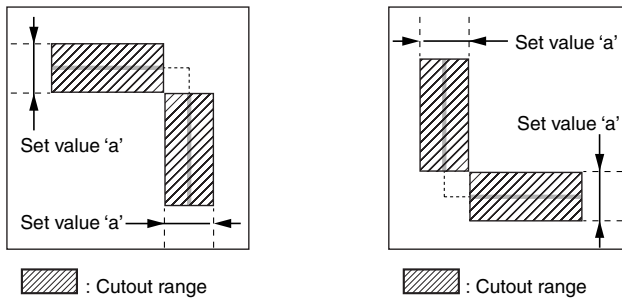

Set the spacing of registration-mark patterns.

Registration-mark pattern mirror 1 Registration-mark pattern mirror 2



The currently set value is indicated by the  blinking cursor.

Use the  and  POSITION keys to change the spacing of registration-mark pattern mirror 1.

The value can be set in the range of 0 to 9.9 mm (0 to 0.398").

- (8) Press the  PAUSE key to return the plotter to READY status.

7.7.4 Setting the Sensing Intervals

If the line segments of registration-mark pattern 3 are narrow, the registration marks cannot be detected even when the slowest registration-mark detection speed has been set. In such a case, set the sensing intervals to the appropriate values. If the interval is set to 0, the registration marks are detected through sampling during movement. If the interval is set to any value between 5 μm and 15 μm , registration marks are detected at intervals of approximately 5 μm , as set.

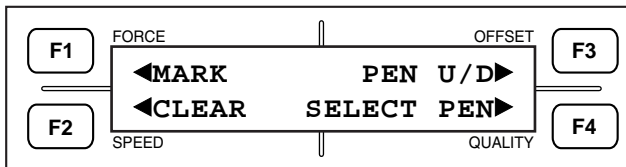

Setting Procedure

- (1) Press the  PAUSE key, followed by the  NEXT PAGE key. The menu below appears.



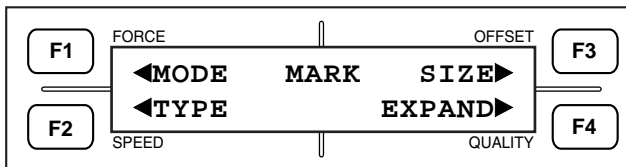

- (2) Press the  key (MARK) to display the menu below.

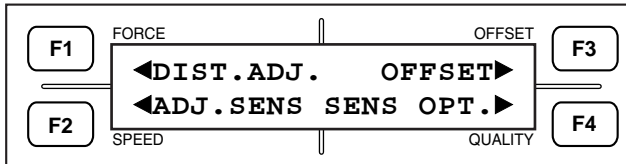

* If the setting of the registration-mark mode (7.2, "Specifying the Registration-Mark Mode") is OFF, the  to  keys are not displayed.

- (3) Press the  key (EXPAND) to display the menu below.



- (4) Press the  key (SENS OPT.) to display the menu below.

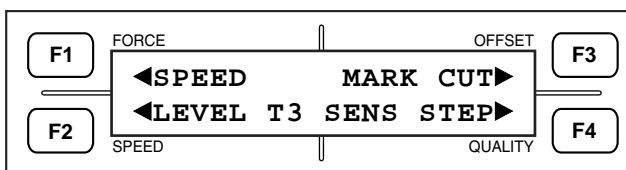

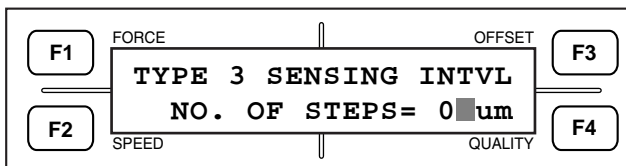

- (5) Press the  key (SENS STEP) to display the menu below.



To move the  blinking cursor, use the  or  POSITION keys.

Use the  and  POSITION keys to change the value.

The value can be set in the range of 0 to 15 (μm). When the displayed setting is satisfactory, press the  ENTER key.

- (6) Press the  PAUSE key to return the plotter to READY status.

8. USING THE OPTIONAL FUNCTIONS

This chapter describes how to use the optional functions which are accessed by selecting OPTION1 or OPTION2.

8.1 Setting the PEN UP SPEED

The PEN UP SPEED function allows you to specify how fast the pen travels while it is raised (in PEN UP status). To cut a medium that is difficult to cut (because it is too stiff or too limp), you must decrease the travelling speed of the lowered pen by setting the SPEED parameter. By increasing the pen's travelling speed in PEN UP status, however, you can shorten the overall cutting time.

Setting Procedure

- (1) Press the  PAUSE key, then press the  NEXT PAGE key until the menu below appears.

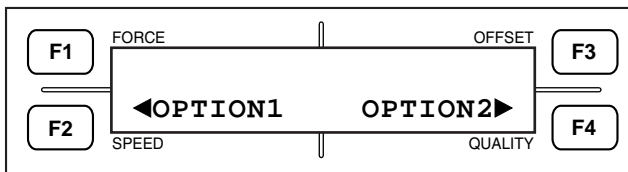



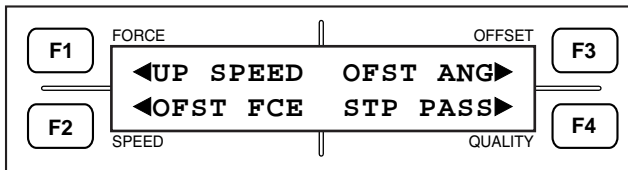

- (2) Press the  (OPTION 1) key to display the menu below.

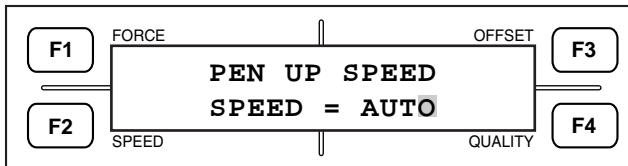

- (3) Press the  (UP SPEED) key to display the menu below.



- (4) Use the  and  POSITION keys to change the PEN UP SPEED setting, which can be specified as AUTO, 10, 20, 30, or 60. When AUTO is selected, the pen's traveling speed in raised status becomes the same as its traveling speed in lowered status (that is, the PEN UP SPEED setting equals the SPEED setting).
- (5) When the displayed setting is satisfactory, press the  ENTER key to register your setting.
- (6) Press the  PAUSE key to return the plotter to READY status.

NOTE

Your PEN UP SPEED setting will be retained in the plotter's RAM even while the plotter is turned off.

8.2 Setting the Cutter Blade's OFFSET FORCE

Upon receiving cutting data, the plotter analyzes the data then performs "initial blade control" to control the orientation of the cutter blade's tip according to the initial angle of rotation required by each line segment defined in the data sent from the computer.

During initial blade control, the plotter cuts the medium for a short distance and then rotates the cutter blade's tip. Since you cannot foresee the direction in which the blade's tip will be facing, the OFFSET FORCE function lets you specify the cutting pressure applied by the cutter blade during initial blade control to a lower level than usual, thus enabling you to separately specify the cutter's offset force. Moreover, your OFFSET FORCE setting can also be used as the cutting force for initial blade control in THICK MODE.

Setting Procedure

- (1) Press the  PAUSE key, then press the  NEXT PAGE key until the menu below appears.

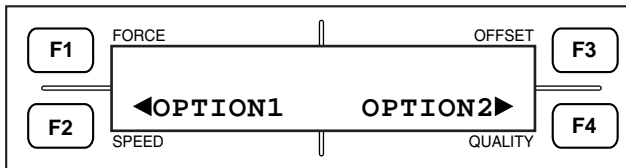



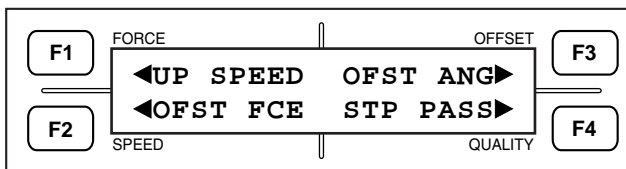

- (2) Press the  (OPTION 1) key to display the menu below.

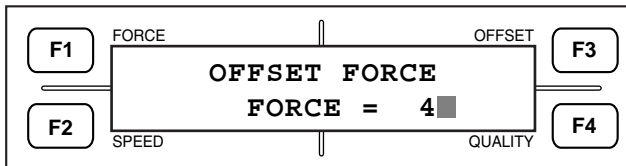

- (3) Press the  (OFFSET FORCE) key to display the menu below.



- (4) Use the  and  POSITION keys to change the OFFSET FORCE setting, which can be specified as any whole number from 1 to 48.
- (5) When the displayed setting is satisfactory, press the  ENTER key to register your setting.
- (6) Press the  PAUSE key to return the plotter to READY status.

NOTE

Your OFFSET FORCE setting will be retained in the plotter's RAM even while the plotter is turned off.

8.3 Setting the Cutter Blade's OFFSET ANGLE

The OFFSET ANGLE function lets you specify a reference angle for determining whether or not the plotter will conduct initial blade control (for an explanation of initial blade control, see Section 7.2, "Setting the Cutter Blade's OFFSET FORCE").

When the reference angle (the OFFSET ANGLE setting) is increased, initial blade control is only performed for large changes of angle, thus shortening the overall cutting time because the time required for initial blade control is reduced. If the OFFSET ANGLE setting is too high, however, your resulting image may not have the intended shape.

Setting Procedure

- (1) Press the  PAUSE key, then press the  NEXT PAGE key until the menu below appears.

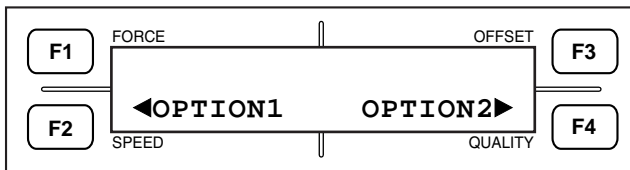



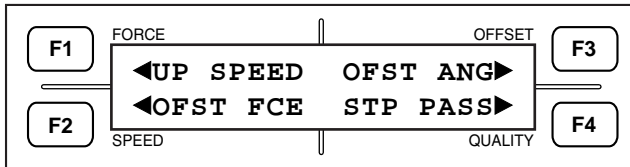

- (2) Press the  (OPTION 1) key to display the menu below.

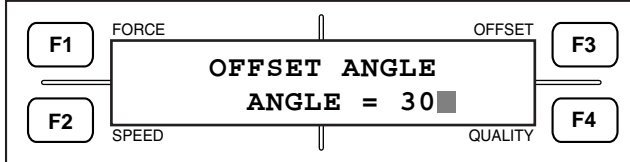

- (3) Press the  (OFFSET ANGLE) key to display the menu below.



- (4) Use the  and  POSITION keys to change the OFFSET ANGLE setting, which can be specified as any whole number from 0 to 60.
- (5) When the displayed setting is satisfactory, press the  ENTER key to register your setting.
- (6) Press the  PAUSE key to return the plotter to READY status.

NOTE

Your OFFSET ANGLE setting will be retained in the plotter's RAM even while the plotter is turned off.

8.4 Setting the STEP PASS

Use this function when the distance between the coordinate points defined in the cutting data is extremely short. The specified STEP PASS value will be used as the minimum unit of distance for processing the cutting data, permitting stability during initial blade control and improved cutting quality.

Setting Procedure

- (1) Press the  PAUSE key, then press the  NEXT PAGE key until the menu below appears.

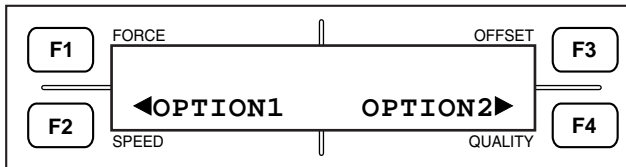



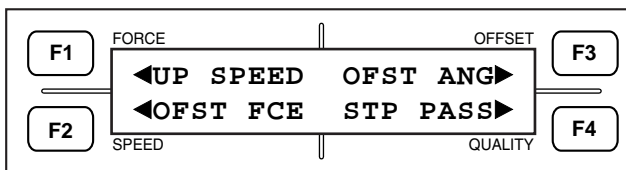

- (2) Press the  (OPTION 1) key to display the menu below.

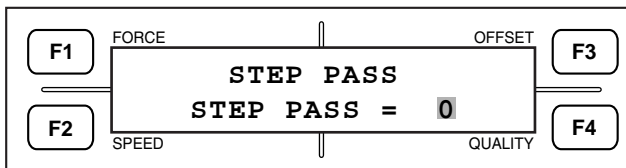

- (3) Press the  (STEP PASS) key to display the menu below.



- (4) Use the  and  POSITION keys to change the STEP PASS setting, which can be specified as any whole number from 0 to 20.
- (5) When the displayed setting is satisfactory, press the  ENTER key to register your setting.
- (6) Press the  PAUSE key to return the plotter to READY status.

NOTE

- Your STEP PASS setting will be retained in the plotter's RAM even while the plotter is turned off.
- If the STEP PASS setting is too high, your resulting image may not have the intended shape. Under normal conditions, it is recommended to perform cutting with the STEP PASS parameter set to zero.

8.5 Selecting the LENGTH UNIT

Your plotter's display panel can show coordinate values in units of either millimeters or inches. This LENGTH UNIT function lets you switch the unit of length shown on the display panel.

Setting Procedure

- (1) Press the  PAUSE key, then press the  NEXT PAGE key until the menu below appears.

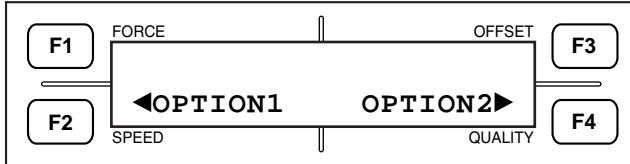



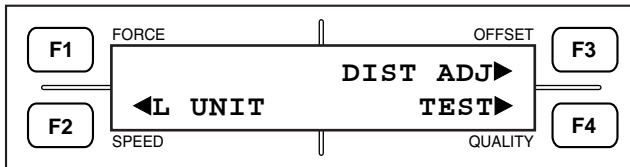

- (2) Press the  (OPTION 2) key to display the menu below.

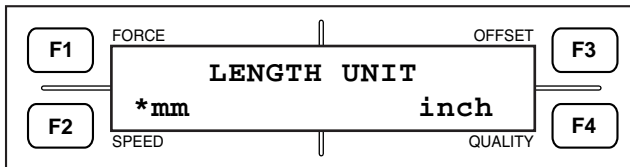

- (3) Press the  (LENGTH UNIT) key to display the menu below.



- (4) The currently selected unit is indicated by the asterisk (*) symbol.
To display coordinate distances in millimeters, press the  (mm) key.
To display them in inches, press the  (inch) key.
- (5) When the displayed setting is satisfactory, press the  ENTER key to register your setting.
- (6) Press the  PAUSE key to return the plotter to READY status.

NOTE

Your LENGTH UNIT setting will be retained in the plotter's RAM even while the plotter is turned off.

8.6 Setting the DISTANCE ADJUST Values

The DISTANCE ADJUST function is used to correct any deviation in the length of line segments during cutting or plotting. The corrective values are input as a percentage of the actual distance of cutting or plotting. For example, when the X= parameter is set to 0.05%, the cutting distance in the X-axis direction will be increased by 0.05%. For a 500-mm cutting distance, therefore, the resulting distance is increased by 0.25 mm ($500 \times 0.05 = 0.25$ mm) to 500.25 mm.

Setting Procedure

- (1) Press the  PAUSE key, then press the  NEXT PAGE key until the menu below appears.

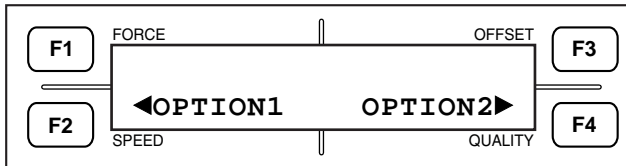



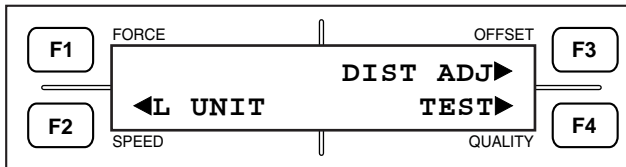

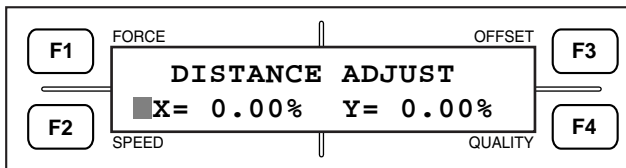

- (2) Press the  (OPTION 2) key to display the menu below.



- (3) Press the  (DISTANCE ADJ) key to display the menu below.



- (4) Press the  (X=) or  (Y=) key to move the blinking cursor and select the coordinate axis to be adjusted.
Next, use the  and  POSITION keys to specify a corrective value from -0.25% to +0.25%.
Repeat the above process for the other parameter, if necessary.
- (5) When the displayed setting is satisfactory, press the  ENTER key to register your setting.
- (6) Press the  PAUSE key to return the plotter to READY status.

NOTE

Your DISTANCE ADJUST settings will be retained in the plotter's RAM even while the plotter is turned off.

9. USING THE SPECIAL FUNCTIONS

This chapter explains how to use special functions which are not used during normal cutting or plotting operations.

9.1 Description of the Special Functions

The following describes the seven special functions.

(1) Enabling or Disabling the “:” and “;” Commands (Only in GP-GL command mode)

While the COMMAND setting is GP-GL, this “:”, “;” COMMAND function lets you switch the ENABLED/DISABLED status for recognizing the input of the “:” and “;” commands from the computer.

If your plotter fails to properly receive the first part of the data transmitted from the computer, the problem may be attributable to these commands. If this happens, change the “:”, “;” COMMAND setting to DISABLED.

(2) Controlling the Pen UP/DOWN Movement by the W COMMAND (Only in GP-GL command mode)

When the W command (for plotting a circle or arc) is output to the plotter while the COMMAND setting is GP-GL, this W COMMAND function determines whether to move the pen to the specified starting point for plotting either in raised status (when the W COMMAND setting is PEN UP) or in the pen’s status (either raised or lowered) just prior to the plotter’s receipt of the W command (when the W COMMAND setting is PEN DOWN).

Note that the PEN UP setting is only valid while the plotter is in CUTTER mode.

(3) Selecting the MODEL EMULATED Response (Only in HP-GL command mode)

While the COMMAND setting is HP-GL, this MODEL EMULATION function lets you specify how the plotter responds when it receives the OI command from the computer.

When the MODEL EMULATED setting is 7550, the plotter sends back “7550B” in response to OI command input. When 7595 is selected, the plotter sends back “7595A” in response to OI command input.

(4) Selecting the CONDITION PRIORITY

The CONDITION PRIORITY function determines whether to place priority on the programmed cutting conditions sent as commands from the computer or on the cutting conditions that have been manually specified at the plotter’s control panel.

When the CONDITION PRIORITY setting is MANUAL, the plotter ignores any specification of cutting conditions in the commands sent from the computer, so the cutting conditions can only be specified or changed at the plotter’s control panel and the specified cutting conditions are retained even while the plotter is turned off.

When PROGRAM is selected, the plotter will assume the latest cutting conditions that have been specified either from its control panel or by command input. When the plotter is turned off, only the cutting conditions that were specified at the control panel will be retained, while any cutting conditions specified by command input will be lost.

(5) Enabling or Disabling SP and J Commands (SP,J COMMAND)

The SP,J COMMAND function lets you determine whether the plotter will acknowledge or recognize the Pen Change command (the J command in GP-GL mode or the SP command in HP-GL command).

When the SP,J COMMAND setting is ENABLED, the current pen will be replaced by the pen corresponding to the PEN No. specified by the Pen Change command.

When DISABLED is selected, all Pen Change command input is ignored.

(6) Selecting the Position for INIT. BLADE CONTROL

The INIT. BLADE CONTROL function determines the position where initial blade control will be performed. (For an explanation of initial blade control, see Section 7.2, "Setting the Cutter Blade's OFFSET FORCE").

When the INIT. BLADE CONTROL setting is 2 mm BELOW, initial blade control will be performed 2 mm below the starting point of cutting.

When OUTSIDE is selected, initial blade control will be performed outside of the effective cutting area.

(7) Enabling or Disabling PEN UP MODE

When the plotter consecutively receives coordinate values within commands specifying pen movement in PEN UP status, the PEN UP MODE function determines whether the pen will move to each of the coordinate points specified or move directly to the final coordinate point.

When the PEN UP MODE setting is ENABLED, the pen moves to each of the coordinate points in the sequence that their data is received.

When DISABLED is selected, when the plotter consecutively receives the coordinate data of multiple points, the pen moves directly to the last coordinate point.

9.2 Setting the Special Functions

Follow the procedure below to specify a special function.

Setting Procedure

- (1) While holding down the ∇ POSITION key, turn on the plotter. The menus for specifying the special functions will be displayed in the sequence below.

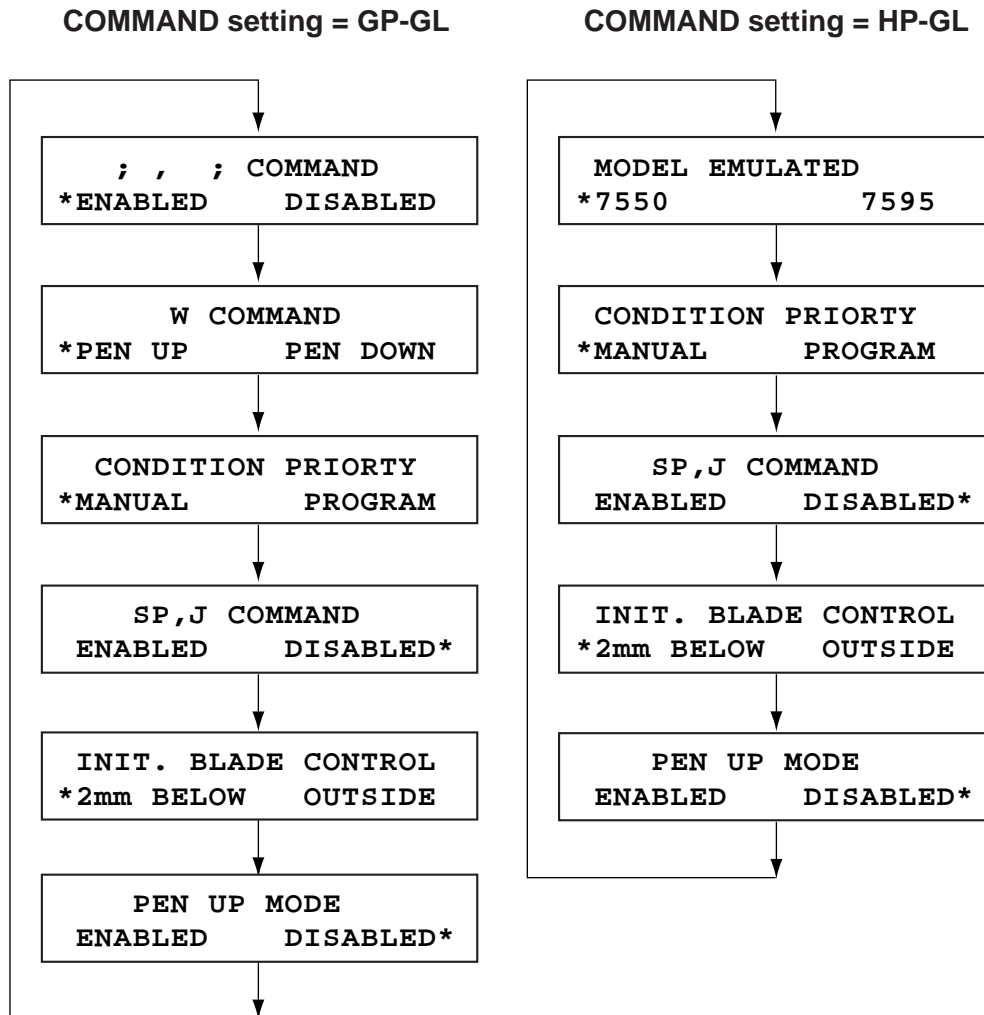

- (2) In each menu, the currently selected setting is indicated by the asterisk (*) symbol. To change the setting, press the **F2** or **F4** key. When the displayed setting is satisfactory, press the **ENTER** key to register your setting. If you do not wish to change a setting, press the **NEXT PAGE** key to skip to the next menu.
- (3) When you are finished specifying the special functions, turn off the plotter.

NOTE

Your settings will be retained in the plotter's RAM even while the plotter is turned off.

10. TEST MODES AND TROUBLESHOOTING PROCEDURES

This chapter explains how to use the plotter's test modes, how to identify and remedy basic problems you may encounter, and what to do if an error message appears.

10.1 Using the TEST Modes

10.1.1 Printing a List of the Currently Selected Conditions





CAUTION

As soon as the F2 (COND. PAT.) key is pressed to select this function in Step (4) below, the pen carriage begins moving. Be sure to keep hands, hair, and so forth away from the plotter's moving parts.

The PRINT CONDITION function prints a list of the plotter's currently selected conditions so you can check them all at once.

Setting Procedure

- (1) Load a medium of A4 size or larger in the plotter.
- (2) Press the  PAUSE key, then press the  NEXT PAGE key until the menu below appears.

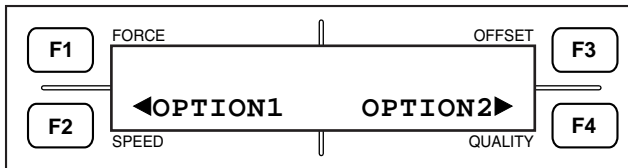

- (3) Press the **F4** (OPTION2) key to display the menu below.

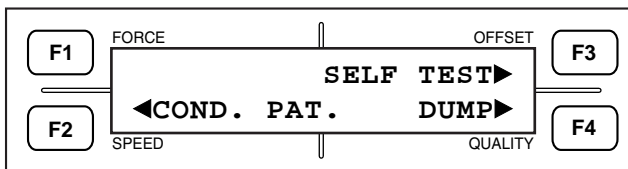

- (4) When the **F2** (COND. PAT.) key is pressed, the menu below appears and the plotter begins printing a list of its currently selected conditions.

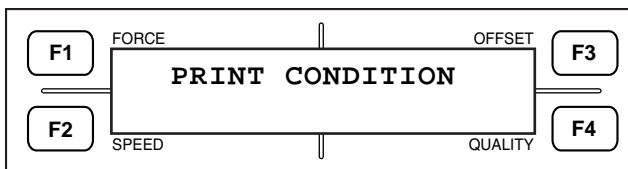

- (5) After the conditions have been printed, the plotter resumes READY status.

10.1.2 Running the SELF TEST





CAUTION

As soon as the F3 (SELF TEST) key is pressed to select this function in Step (4) below, the pen carriage begins moving. Be sure to keep hands, hair, and so forth away from the plotter's moving parts.

The SELF TEST function prints a test pattern that allows you to check the plotter's operation independent of its interface functions.

Setting Procedure

- (1) Load a medium of A3 size or larger in the plotter.
- (2) Press the  PAUSE key, then press the  NEXT PAGE key until the menu below appears.

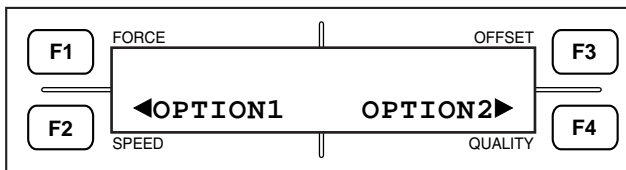

- (3) Press the  (OPTION2) key to display the menu below.

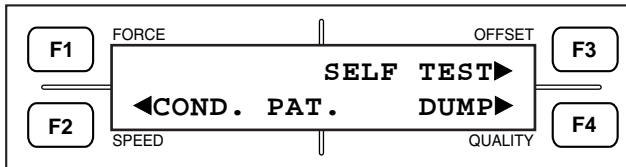

- (4) When the  (SELF TEST) key is pressed, the menu below appears and the plotter begins plotting the self test pattern.

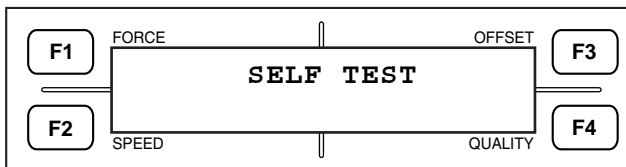

- (5) The plotter repeatedly plots the self test pattern until it is turned off. To terminate the self test, therefore, turn off the plotter.

10.1.3 Using the Character Dump Mode





CAUTION

As soon as the F4 (DUMP) key is pressed to select this function in Step (4) below, the pen carriage begins moving. Be sure to keep hands, hair, and so forth away from the plotter's moving parts.

This CHAR DUMP function enables advanced users to check whether or not the plotter is properly receiving the data sent from the computer. If the data printed by the CHAR DUMP function does not match the data actually sent from the computer, check your RS-232C interface conditions or COMMAND setting once more. These settings may be incorrectly set or may not match your software application's settings.

Setting Procedure

- (1) Load a medium of A4 size or larger in the plotter.
- (2) Press the  PAUSE key, then press the  NEXT PAGE key until the menu below appears.

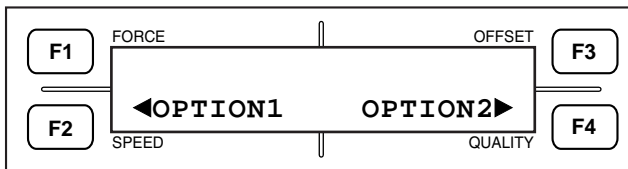

- (3) Press the **F4** (OPTION2) key to display the menu below.

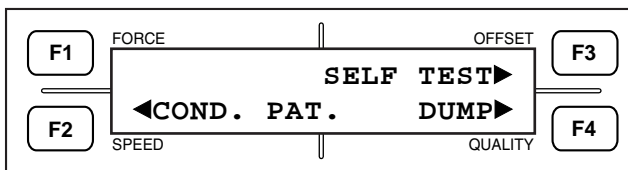

- (4) When the **F4** (DUMP) key is pressed, the menu below appears and the plotter enters DUMP mode.

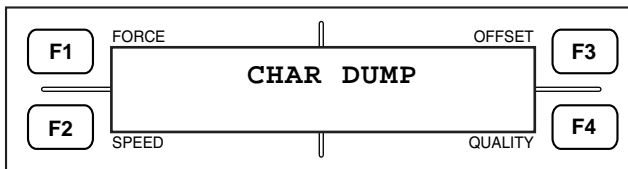

- (5) When you send data from the computer to the plotter, the plotter begins printing that data.
- (6) To exit the DUMP mode, turn off the plotter.

NOTE

- In DUMP mode, the plotter prints the data it receives as ASCII codes. Control codes are printed in smaller characters as two-digit hexadecimal values.
- In response to the receipt of a READ-type command, the plotter sends back dummy data except when requested to output its current status.

10.2 Troubleshooting Procedures

If your plotter is not operating properly, try the solution(s) described in the following tables before contacting your sales representative or nearest Graphtec vendor to request a service call.

10.2.1 The Plotter Doesn't Operate After Being Turned On

Symptom	Cause	Solution
The control panel's POWER lamp does not light. The display panel is blank.	The plotter isn't being supplied with power.	Check that the power cord is properly plugged into the plotter's AC inlet and the electrical outlet.
The POWER lamp lights but the plotter doesn't operate.	The plotter has broken down.	Contact your sales representative or nearest Graphtec vendor.
The control panel's POWER lamp lights, but the plotter doesn't operate. The control panel's PAUSE lamp is flashing. The display panel is blank.	The ROM and RAM are defective.	Contact your sales representative or nearest Graphtec vendor.
The control panel's POWER lamp lights, but the plotter doesn't operate. The "Sum-ck-ROMERROR!!" message appears on the display panel.	The ROM and RAM are defective.	Contact your sales representative or nearest Graphtec vendor.

10.2.2 The Cut Results Are Unsatisfactory

Symptom	Cause	Solution
<ul style="list-style-type: none"> The cut corners are too round The cut corners are too pointed 	The OFFSET setting is not suitable for the blade type being used.	Adjust the OFFSET setting. → <u>Corners are too rounded</u> : Raise the OFFSET value. → <u>Corners are too pointed</u> : Lower the OFFSET value.
The cutter blade wobbles only when it starts to cut	The blade does not rotate smoothly in the holder.	Remove any foreign matter in the holder.
	The OFFSET FORCE setting is too low.	Raise the OFFSET FORCE setting. *The cutter pen's OFFSET FORCE and the cutting FORCE are two different functions.
	The spring has come loose from the CB09UA blade.	Replace the blade with a new one equipped with a spring.
<ul style="list-style-type: none"> Solid lines are cut as dotted lines (the blade skips). The cutter blade seems to undulate when cutting solid lines. 	The cutter's blade is extended too far.	Adjust the extended length of the cutter's blade.
	The cutting speed is too fast.	Lower the SPEED setting to reduce the cutting speed.
Curved lines become zigzagged.	The software application's cutting data is too coarse.	Rewrite the software application's cutting data to specify more coordinate points for smoother curves.
	The OFFSET ANGLE setting is too low.	Raise the OFFSET ANGLE setting.
<ul style="list-style-type: none"> The medium's corners peel off. The medium peels off when cutting small characters. 	The cutter's blade is extended too far.	Adjust the extended length of the cutter's blade.
	The OFFSET setting is not suitable for the blade type being used.	Adjust the OFFSET setting.
	The cutting speed is too fast.	Lower the SPEED setting to reduce the cutting speed.
	The cutter's blade is too dull to cut the medium.	Replace the blade.
	The QUALITY setting is too high.	Lower the QUALITY setting.

Symptom	Cause	Solution
<ul style="list-style-type: none"> The blade cuts even into the backing sheet. 	The cutter's blade is extended too far.	Adjust the extended length of the cutter's blade.
	The cutting FORCE setting is too high.	Lower the FORCE setting.
<ul style="list-style-type: none"> The blade falls out of the cutter plunger. 	The cutter plunger's diameter is too large for the blade being used.	Use a cutter plunger of the proper diameter for your blade.
<ul style="list-style-type: none"> The medium is being cut but remaining scraps are hard to remove. The processed film cannot be picked up with a retack sheet. 	The retack sheet's adhesion is too weak.	Use a retack sheet with greater adhesive power.
	The medium gets entangled where cutting has been performed.	<ul style="list-style-type: none"> Retract the extended length of the cutter's blade. Lower the cutting FORCE setting.
	After processing, the medium was left without promptly peeling off remaining scraps.	Peel off remaining scraps as promptly as possible.
<ul style="list-style-type: none"> The cutter unit generates an abnormal noise during operation. The medium becomes discolored wherever the blade passes. 	The tip of the cutter plunger is rubbing against the medium.	Adjust the extended length of the cutter's blade and the cutting FORCE setting.
<ul style="list-style-type: none"> The resulting image is not the specified size. 	The software application and plotter are not set to the same STEP SIZE setting.	Specify the same STEP SIZE setting for both your software application and for the plotter.
	Scaling is enabled at your software application.	Check the scaling setting.
<ul style="list-style-type: none"> The PROMPT lamp lights when data is output (an off-scale error has occurred) Certain areas of the medium cannot be cut. 	The software application and plotter are not set to the same STEP SIZE setting.	Specify the same STEP SIZE setting for both your software application and for the plotter.
	Computer output to the plotter contains data specifying coordinate points outside of the specified AREA setting.	Re-specify the AREA setting.
	Computer output to the plotter specifies an image that exceeds the effective area.	Rewrite your data to specify a smaller image.

Symptom	Cause	Solution
<ul style="list-style-type: none"> • Cutting conditions cannot be retained or changed. 	The CONDITION PRIORITY setting is PROGRAM.	Switch the setting to MANUAL.
	The ENTER key wasn't pressed after changing a setting.	Check your setting procedure.
<ul style="list-style-type: none"> • Characters and lines become deformed when plotting. 	The plotter is set to Cutter mode.	At the CONDITIONS menu, switch the pen type setting from a blade type to PEN.
<ul style="list-style-type: none"> • The plotter does not cut/plot the specified length (slight error in distance precision). 	The DIST. ADJ. function is improperly specified.	Adjust the distance precision.
<ul style="list-style-type: none"> • Characters become deformed. • Complex images become deformed. 	The STEP PASS setting is too high.	Lower the STEP PASS setting.
<ul style="list-style-type: none"> • The starting and end points of an image do not match. 	The cutting data has not been written so that the points meet.	Check your cutting data by plotting it with a pen.
	The OFFSET FORCE setting is too weak.	Raise the OFFSET FORCE setting.
	The medium's backing sheet is too limp.	Switch to a medium with a stiff backing sheet.
	The blade does not rotate smoothly.	Check if any foreign matter has adhered to the blade. If so, remove it.

10.2.3 Creasing/Scoring

Symptom	Cause	Solution
The medium is damaged or torn.	The pen force (creasing force) is excessive.	Reduce the pen force (creasing force).
	The plotter has been reciprocated too many times.	Reduce the set count of reciprocation for creasing.
	With corrugated cardboard, the strength of the media varies depending on the direction of the flute.	Change the pen force (creasing force) according to the flute direction (X and Y directions).

10.2.4 The Coordinate Axes Cannot Be Correctly Aligned

Symptom	Cause	Solution
During automatic registration mark alignment, the MARK SEARCH ERROR message is displayed or the coordinate axes cannot be properly aligned.	There is foreign matter or plotting on the area where the mark sensor passes.	Ensure that the detection area is free of foreign matter or plotting.
	The medium is loose or wrinkled where the mark sensor passes.	<ul style="list-style-type: none"> • Firmly secure the medium so that it will not come loose. • Use a medium without any wrinkles, creases, or folds.
	The medium is not white.	Use a white medium.
	The registration marks are not printed using black ink.	Print the registration marks using black ink.
	The lines of the printed registration marks are too thin or are not cleanly printed.	Print clean registration marks with a line width of at least 0.3 mm.
	Strong light is irradiating the vicinity of the mark sensor.	Ensure that no light from an external source irradiates the vicinity of the mark sensor.
	If none of the above solutions are feasible, perform registration mark alignment manually.	

10.3 Error Messages

10.3.1 General Error Messages

Error message	Cause	Solution
[X POSITION ALARM POWER OFF THEN ON] or [Y POSITION ALARM POWER OFF THEN ON] • The beeper sounds. • The PROMPT lamp lights.	The cutting conditions specified for the medium to be cut are unreasonable.	Lower the SPEED setting. Lower the FORCE setting.
	Something is obstructing the pen carriage's movement.	After removing the obstacle, turn the plotter off then back on again.
	An external load was applied to the pen carriage during operation.	After removing the obstacle, turn the plotter off then back on again.
	Fragments of the cut medium have entered into the plotter's moving parts and are impeding their movement.	After removing the obstacle(s), turn the plotter off then back on again.
	The table of acceleration rates is faulty.	* If this problem occurs frequently, contact your sales representative or nearest Graphtec vendor.

10.3.2 Error Messages in GP-GL Command Mode

Error message	Cause	Solution
ERROR 1 Command Error	The plotter received an unrecognizable command.	
	When turning on the plotter to which your software application has output data, noise mixed into the data input.	Press the plotter's ENTER key.
	Your software application's output device setting has changed.	Configure your software application menu to permit Graphtec plotter control. Re-specify the software application's interface conditions.
	The plotter's interface conditions have changed.	Re-specify the plotter's interface conditions.
ERROR 4 Parameter Overflow	The numeric parameter of an input command exceeds its permissible range.	
	Your software application's output device setting has changed.	Configure your software application menu to permit Graphtec plotter control. Re-specify the software application's interface conditions.
	The plotter's interface conditions have changed.	Re-specify the plotter's interface conditions.
ERROR 5 I/O Error	An error related to the receipt of data occurred within the interface.	
	Your software application's output device setting has changed.	Configure your software application menu to permit Graphtec plotter control. Re-specify the software application's interface conditions.
	The plotter's interface conditions have changed.	Re-specify the plotter's interface conditions.

10.3.3 Error Messages in HP-GL Command Mode

If any of the HP-GL command error messages listed in the following table is displayed, the cause can nearly always be traced to one of the causes below:

- (1) The software application's output device setting has changed; or
- (2) The plotter's interface conditions have changed.

If a command error occurs while the COMMAND setting is HP-GL, therefore, first check the two corresponding points below.

- (1) Configure the software to drive your plotter and ensure that the software's interface conditions are correctly set; and
- (2) Re-specify the plotter's interface conditions.

Error message	Cause	Solution
ERROR 1 Instruction not recognized	An unrecognizable command was issued.	Issue a command that the plotter will recognize.
ERROR 2 Wrong number of parameters	A command was issued with the wrong number of parameters.	Re-issue the command with the correct number of parameters.
ERROR 3 Out of range parameters	A command containing an invalid parameter was issued.	Re-issue the command with its parameters specified within their permissible ranges.
ERROR 5 Unknown character set	An unknown character set was specified.	Specify a character set that the plotter will recognize.
ERROR 6 Position overflow	A command was issued with coordinate data that exceeds the effective cutting/plotting area.	Issue the command with its coordinate data specified within the effective cutting/plotting area.
ERROR 7 Buffer overflow	The data being input exceed the capacity of the downloadable character buffer, polygon buffer, etc.	Increase the buffer size.
ERROR 10 Invalid I/O output request	While executing an output command, the plotter received another output command.	Check the programmed data.
ERROR 11 Invalid byte following ESC	Receipt of the ESC character was followed by an invalid byte.	Check the programmed data.
ERROR 12 Invalid byte in I/O Control	A device control command containing an invalid byte was received.	Check the programmed data.
ERROR 13 Out of range I/O parameter	An I/O control command was issued with parameter outside of the permissible numeric range.	Check the programmed data.
ERROR 14 Too many I/O parameters	An I/O control command was issued with too many parameters.	Check the programmed data.
ERROR 15 Error in I/O transmission	During data transfer, a framing error, parity error, or overrun error occurred.	Check the settings of the RS-232C interface conditions.
ERROR 16 I/O buffer overflow	The I/O buffer received data faster than it could process the data.	Check the settings of the RS-232C interface conditions.

11. INTERFACES

This chapter explains the procedures for setting up the plotter's interfaces to exchange data with a computer. This plotter comes standard with an RS-232C serial interface and a Centronics-compatible parallel interface. The plotter's interface mode is automatically selected according to the type of data being transmitted to the plotter.

11.1 Setting Up the Centronics-Compatible Parallel Interface

To use the Centronics-compatible parallel interface, it is only necessary to specify the COMMAND mode and either the STEP SIZE parameter (when the COMMAND setting is GP-GL) or the ORIGIN parameter (when the COMMAND setting is HP-GL).

For instructions on setting the required parameters, see Section 10.5, "Selecting the COMMAND Mode," Section 10.3, "Specifying the STEP SIZE," and Section 6.1, "Selecting the ORIGIN POINT Position in HP-GL Mode."

11.2 Setting Up the RS-232C Serial Interface

To use the RS-232C Serial interface, it is necessary to specify the COMMAND mode, either the STEP SIZE parameter (when the COMMAND setting is GP-GL) or the ORIGIN parameter (when the COMMAND setting is HP-GL), and the RS-232C interface conditions. At the plotter's control panel, you can register up to three different sets of RS-232C interface conditions as COND Nos. RS-1, RS-2, and RS-3, thus allowing you to quickly and easily switch the interface conditions to suit your application.

Set the interface conditions to the same settings for your software application and for the plotter. If they are incorrectly set, the plotter may display an error message, fail to properly receive all of the data transmitted from the computer, or malfunction. In such cases, check your interface conditions once more.

For instructions on setting the required parameters, see Section 10.5, "Selecting the COMMAND Mode," Section 10.3, "Specifying the STEP SIZE," Section 6.1, "Selecting the ORIGIN POINT Position in HP-GL Mode," and Section 10.4, "Specifying the RS-232C Interface Conditions."

Factory-Preset Interface Conditions

COND No. RS-1

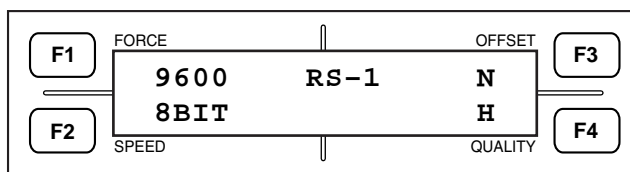

COND No. RS-2

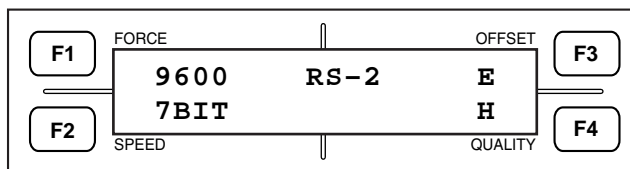

COND No. RS-3

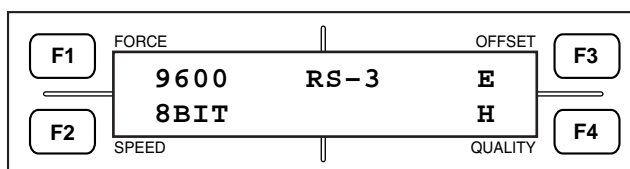

11.3 Specifying the STEP SIZE

The STEP SIZE function can only be specified when the COMMAND setting is GP-GL. It specifies the minimum unit of distance travelled by the pen in step units. The STEP SIZE parameter can be set to 0.100, 0.050, 0.025, or 0.010 mm. Be sure to set the STEP SIZE parameter to the same setting at both your software application and at the plotter.

Setting Procedure

- (1) Press the  PAUSE key, then press the  NEXT PAGE key until the menu below appears.

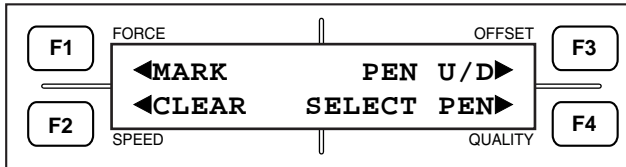

- (2) Press the  NEXT PAGE key to display the menu below.

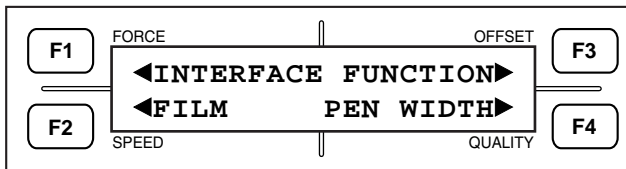

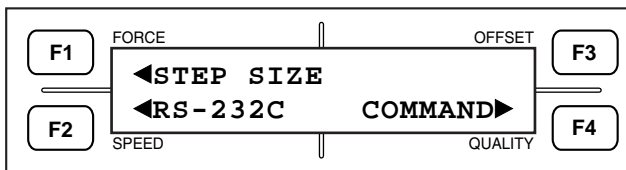

- (3) Press the  (INTERFACE) key to display the menu below.



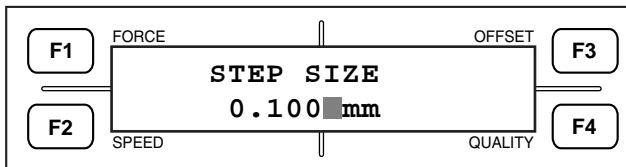

- (4) Press the  (STEP SIZE) key to display the menu below.



- (5) Use the  and  POSITION keys to set the STEP SIZE setting to either 0.010, 0.025, 0.050, or 0.100 mm.

If you do not wish to change the STEP SIZE setting at this time, press the  NEXT PAGE key.

- (6) When the displayed setting is satisfactory, press the  ENTER key to register your setting.

- (7) Press the  PAUSE key to return the plotter to READY status.

11.4 Specifying the RS-232C Interface Conditions

Be sure to set the interface conditions to identical settings at both your software application and at the plotter.

Setting Procedure

- (1) Press the  PAUSE key, then press the  NEXT PAGE key until the menu below appears.

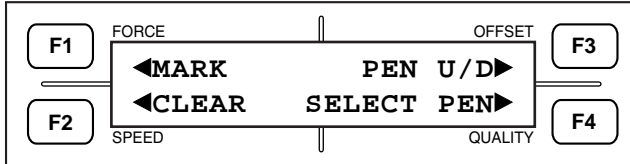

- (2) Press the  NEXT PAGE key to display the menu below.

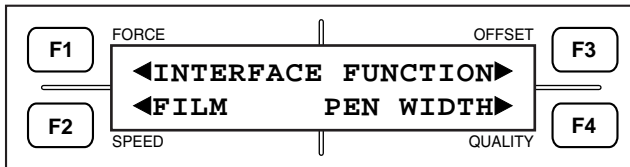

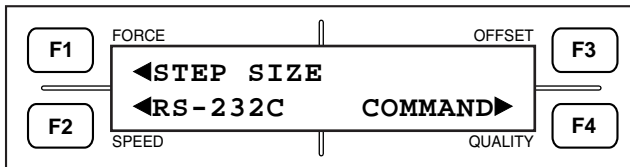

- (3) Press the  (INTERFACE) key to display the menu below.



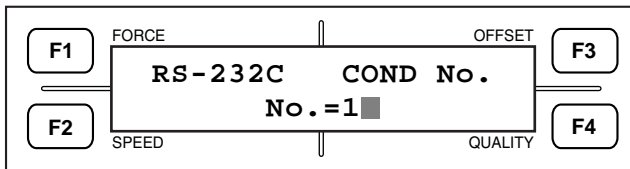



- (4) Press the  (RS-232C) key to display the menu below.

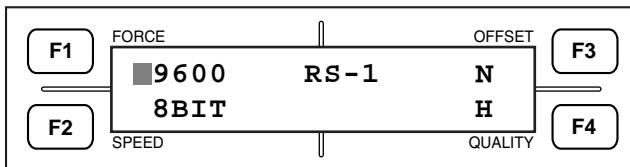

- (5) Use the  and  POSITION keys to display the COND No. corresponding to the set of interface conditions you wish to change, then press the  ENTER key to display the menu below.



- (6) Use the function keys ( to ) to move the  blinking cursor to the parameter you wish to change.

To actually change the displayed setting, use the  and  POSITION keys.

If you do not wish to change the settings for the selected COND No. at this time, press the  NEXT PAGE key.

The parameter values are as follows:



Baud rate : 19200, 9600, 4800, 2400, 1200, 600, 300

Data length : 7BIT (7bits), 8BIT (8bits)

Parity : N (none), E (even), O (odd)

Handshake : H (hardwire), X (X-on/X-off), E (Enq/Ack; selectable in HP-GL command mode only)

Select the appropriate values to match those of your application program.

- (7) When the displayed settings are satisfactory, press the  ENTER key to register your setting.
- (8) Press the  PAUSE key to return the plotter to READY status.

11.5 Selecting the COMMAND Mode

The COMMAND function selects the plotter's command mode for use with either GP-GL or HP-GL commands. Select the COMMAND setting to match your software application.

Setting Procedure

- (1) Press the  PAUSE key, then press the  NEXT PAGE key until the menu below appears.

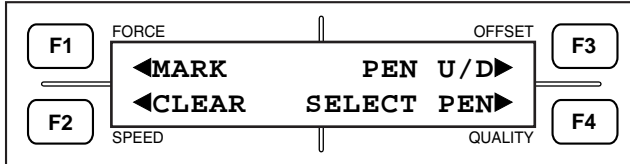

- (2) Press the  NEXT PAGE key to display the menu below.

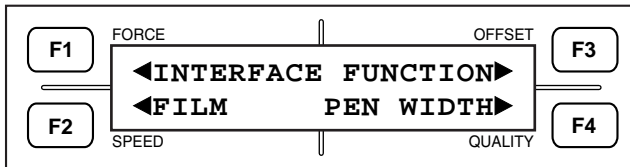

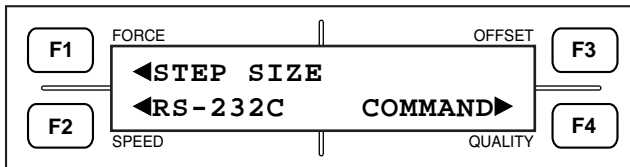

- (3) Press the  (INTERFACE) key to display the menu below.

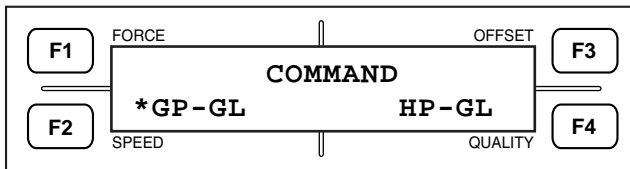

- (4) Press the  (COMMAND) key to display the menu below.



- (5) The currently selected setting is indicated by the asterisk (*) symbol.
 To set the COMMAND mode to GP-GL commands, press the  (GP-GL) key.
 To set the COMMAND mode to HP-GL commands, press the  (HP-GL) key.
- (6) When the displayed setting is satisfactory, press the  ENTER key to register your setting.
- (7) The plotter runs its initialization routine and then assumes READY status.

12. SPECIFICATIONS

12.1 General Specifications

	FC4210-60
CPU	32-bit CPU
Configuration	Flatbed cutting plotter
Drive system	Fully-digital servo drive
Maximum cutting area	860 mm × 600 mm
Loadable media width	666 mm
Maximum cutting speed	65 cm/s
Specifiable cutting speeds	1, 2, 3, 4, 5, 6, 7, 8, 9, 10, 15, 20, 25, 30, 35, 40, 45, 50, 55, 60, 65 cm/s
Cutting force	0.098 to 5.88 N (10 to 600 gf)
Minimum character size	Approximately 5 mm for alphanumeric characters (varies depending on the media and fonts used)
Mechanical resolution	0.005 mm
Programmable resolution	GP-GL : 0.1/0.05/0.025/0.01 mm HP-GL™: 0.025 mm*1
Repeatability precision *2	0.1 mm or less
Distance precision *2	Traveling distance × ±0.2% or less or ±0.1 mm or less, whichever is greater
Perpendicular precision *2	0.4/610 mm or less
Registration-mark reading precision *3	Within 0.2 mm
Maximum number of tools	2
Compatible blade type	Supersteel blade
Tool/pen types	Creasing/scoring tool, water- and oil-based ballpoint pens
Usable cutting media	Marking film (polyvinyl, fluorescent, reflective) Cardboard of a thickness of 0.5 mm or less Paper of a thickness of 0.5 mm or less (pattern paper, oilboard) *4 F,G grade microflute Clear sheets for packaging
Interface	RS-232C or Centronics (automatically selected)
Buffer capacity	2 MB
Resident command sets	GP-GL and HP-GL™ (selected from the control panel)
LCD display	20 characters × 2 lines
Rated power-supply voltage	100 to 120 VAC ±10%, 50/60 Hz; 220 to 240 VAC ±10%, 50/60 Hz
Power consumption	120 VA or less
Operating environment	10°C to 35°C, 35% to 75% rh (no condensation allowed)
External dimensions (W×D×H)	Approx. 1172 mm × 960 mm × 200 mm
Weight (without stand)	Approx. 27 kg

*1 : HP-GL™ is a registered trademark of Hewlett-Packard Company.

*2 : Depends on Graphtec-designated media used and the currently selected cutting conditions.

*3 : As determined by reading the plotter's resident pattern using the pen (included with the plotter) and high-grade paper.

*4 : For use with the CB15U or CB15U-K30 cutter blade.

12.2 Option

Name	Part no.
Stand	ST0032

12.3 External Dimensions

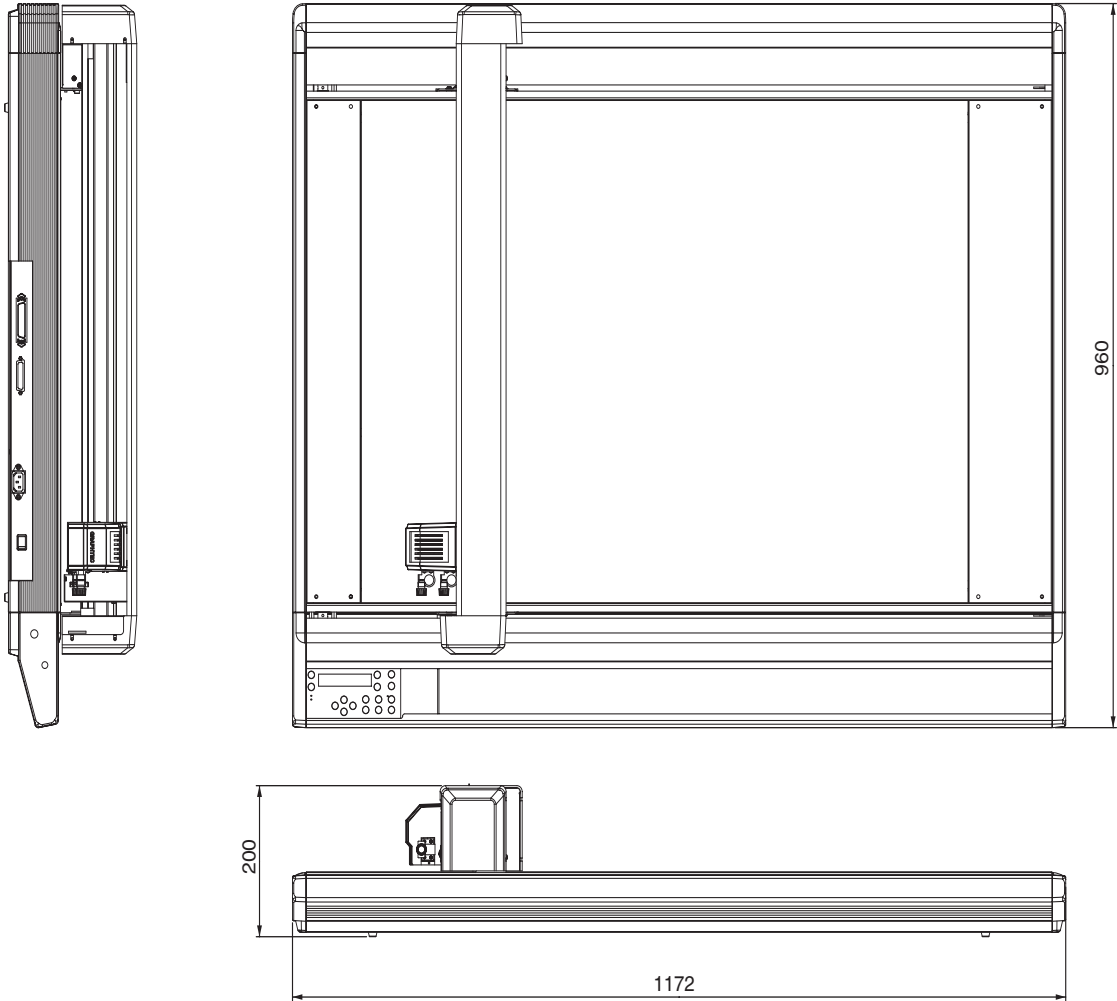

Unit: mm
Dimensional precision error: ±5 mm

■ Symbol ▶

“,” command	9-1
2-point reading	7-10
2-point reading, setting of	7-10
3-point reading	7-11
3-point reading, setting of	7-11

■ A ▶

Adhesive mat	xi
Adhesive sheet	xii
ADJ. SENS	7-21, 7-23
ADJ. SENS+	7-23
Adjustment amount	4-1
Adjustment amount, setting of	4-1
ADJUST SENSOR+, setting of	7-23
ADJUST SENSOR, setting of	7-21
AREA	6-2
Automatic Registration-Mark Recognition	7-1

■ B ▶

Blade tip, initial position of	9-1
Blade type, setting of	4-4
Buffer memory	5-2
Buffer memory, clearing of	5-8

■ C ▶

CANCEL/VIEW key	3-2
CB09UA	2-1
CB15-05S	2-1
CB15-10C	2-1
CB15U	2-1
CB15U-K30	2-1
CB15UA	2-1
Centronics	3-4
Centronics cable	3-4
Centronics interface	1-2
Centronics interface, setting of	11-1
Command, setting of	11-5
CONDITIONS key	3-2
CONDITIONS key, display when pressed	4-3
Condition printing mode, setting of	10-1
Condition setting	4-2
Condition, priority of	9-1
Coordinate axis, rotation of	6-4
Copy function, use of	5-2
COPY key	3-2
COUNT, setting of	4-6
Creasing force	4-1, 4-7
Creasing mode, setting of	4-5
Creasing, count of	4-6
Creasing, spacing of	4-6
Creasing, start position of	4-7
Cutter plunger	2-2
Cutter plunger, name of each part for	2-2
Cutter plunger, selection of the condition-setting area for	4-2

Cutting blade, method for replacement of	2-3
Cutting blade, protrusion of	4-1
Cutting blade, types and features of	2-1
Cutting conditions, setting of	4-3
Cutting data	5-2
Cutting force	4-1, 4-7
Cutting force and pen force (creasing force), setting of	4-7
CUTTING PRO	4-12

■ D ▶

Data length	11-4
DIST ADJ.	7-20
DISTANCE ADJUST, setting of	7-19
Distance-adjustment value, setting of	8-6
Dump Mode, use of	10-3

■ E ▶

ENTER key	3-2
Error display	10-9
EXPAND	4-1
EXPAND, setting of	7-20

■ F ▶

Function select key	3-1
---------------------------	-----

■ G ▶

GP-GL commands	6-1
GP-GL commands, error display of	10-10

■ H ▶

Handshaking	11-4
HP-GL commands	6-1
HP-GL commands, error display of	10-11
HP-GL settings, origin setting for	6-1

■ I ▶

Interface	11-1
-----------------	------

■ L ▶

LENGTH UNIT, setting of	8-5
Level	7-29

■ M ▶

Manual reading, setting of	7-8
Mark cutting for mirror	7-13
MENU key	3-2
Menu list	3-3
MENU mode	3-1
MIRROR	6-7
MIRROR mode, setting of	6-7

N ▶

NEXT PAGE key 3-2

O ▶

OFFSET 7-25
OFFSET ANGLE, setting of 8-3
OFFSET FORCE, setting of 8-2
OFFSET, amount of 7-3
“OT” command 9-1
Operation panel, description of 3-1
Optional functions, use of 8-1
ORIGIN POINT 6-1
ORIGIN key 3-2
Out of range 9-2

P ▶

Paper on which the Registration Mark
cannot be detected 7-4
Parity 11-4
PAUSE key 3-2
Pen carriage 1-2
Pen change command 9-2
Pen conditions, setting of 4-1
Pen force 4-1, 4-7
Pen holder 1-2
Pen number 5-9
Pen setting, setting of 5-9
PEN UP MOVE, enabling/disabling of 9-2
PEN UP SPEED 8-1, 8-2, 8-3, 8-4, 8-5
PEN UP SPEED, setting of 8-1
PEN UP/DOWN 5-7
PEN WIDTH, setting of the correction value for 5-5
Plotting area, setting of 6-2
Plotting origin 7-3
Plotting origin, setting of 5-1
Plunger cap 2-3
POSITION key 3-2
POWER lamp 3-1
PROMPT lamp 3-1

Q ▶

QUALITY 4-1
QUALITY, setting of 4-9

R ▶

Reading range required for
Registration-MARK CUT 7-30
Registration-MARK CUT, setting of 7-30
Registration-Mark Level, setting of 7-28
Registration-MARK Mode, setting of 7-5
Registration-MARK OFFSET, setting of 7-3, 7-25
Registration-mark pattern 7-1
Registration-mark pattern, setting of 7-14

Registration-mark pattern,
spacing of 7-2, 7-14, 7-15, 7-16, 7-31
Registration-Mark Recognition 7-8
Registration-Mark Recognition 7-2
Registration-Mark Recognition movement-distance
setting 7-6
Registration-Mark Recognition, setting of
the detection speed for 7-27
Registration-MARK SIZE, setting of 7-18
ROTATE 6-4
RS-232C 3-4
RS-232C interface 1-2
RS-232C interface, setting of 11-1
RS-232C interface, setting of the transfer
conditions for 11-3

S ▶

Sandblast rubber 2-1
SELF TEST mode, use of 10-2
SENS OPT. 7-27
SENSING INTVL 7-32
SENSING INTVL, setting of 7-32
Serial cable 3-4
SORT 6-9
SORT function, setting of 6-9
SPACING, setting of 4-6
Special functions, use of 9-1
SPEED 4-1
SPEED 7-28
SPEED, setting of 4-8
START, setting of 4-7
STEP PASS, setting of 8-4
STEP SIZE, setting of 11-2
Strip film 2-1

T ▶

Test 4-11
Test 1 4-11, 4-13
Test 2 4-11, 4-13
TEST key 3-2
Test mode, troubleshooting for 10-1
THICK 6-6
THICK mode, setting of 6-6
Type name, response for 9-1

W ▶

“W” command 9-1
When Automatic Registration-Mark Recognition
cannot be used 7-4
Writing panel 1-2

Y ▶

Y bar 1-2

- The information contained in this manual may be changed without prior notice.

FC4210-60 User's Manual
(FC4210-UM-151)

Issued September 1, 2001
First edition, first printing 000

Issued by

GRAPHTEC CORPORATION

Shinano-cho 503-10, Totsuka-ku, Yokohama-shi, Kanagawa, Japan
